

ST5 SERIES

Medium Duty Hydraulic Cylinders

Cylinder Design Features

Piston Rod ●

High Strength Alloy Steel (SAE4140). **STARNITE™** (Nitrocarburation) treatment on the rod gives better corrosion-resistant properties (out performs 12-micron, (.0005 in.) chromium electroplating by ratio up to 20:1.), Improved wear resistance, better lubrication retention, dent resistance without induction hardening (65-70Rc), environmentally friendly, no surface pitting, flaking, or hydrogen embrittlement. The finish created by the process is a lustrous black. (available up to 6 ft of stroke) (Available in Stainless Steel)

Wiper ●

The Urethane wiper is designed to wipe off abrasive dust and contaminants on the retract stroke to ensure long life for the seals, rod bushing and piston rod. (temperature: -50° to 230°F)

Rod lips seal ●

Our New Design with a real rod u-cup is completely self compensating for zero leakage at all pressures (temperature: -50° to 230°F)

Self Centering Cushion Spud ●

Self centering design allows for close tolerance and min. wear. Optional at extra charge. For faster cycle time and increased productivity, maximum performance, economical, flexible for even the most demanding applications, reduces shock and machine noise, lower maintenance costs, can be supplied at head, cap or both ends.

One-Piece Iron Piston (U-cup Design) Std. ●

One piece design for maximum strength and bearing surface. Anaerobic adhesive is used to permanently lock and seal the piston to the rod. 3 different styles of piston available.

Piston Lip Seal (std) ●

Lip-type low friction urethane piston seals are pressure energized and wear compensating for low friction and long life (temperature: -50° to 230°F)

Piston Wear Ring ●

Nylon material is designed for low friction, and to ensure minimum wear in the cylinder's tubing in side load application. Eliminates metal-to-metal contact.

O-ring Tube End Seals ●

Nitrile O-ring design is pressure compensating and reusable. Pressure-actuated cylinder body-to-head and cap

Porting ●

NPT ports are standard. SAE Straight thread "O"Ring Ports are optional at no extra cost. Standard port position is number 1. Specify if another location is needed.

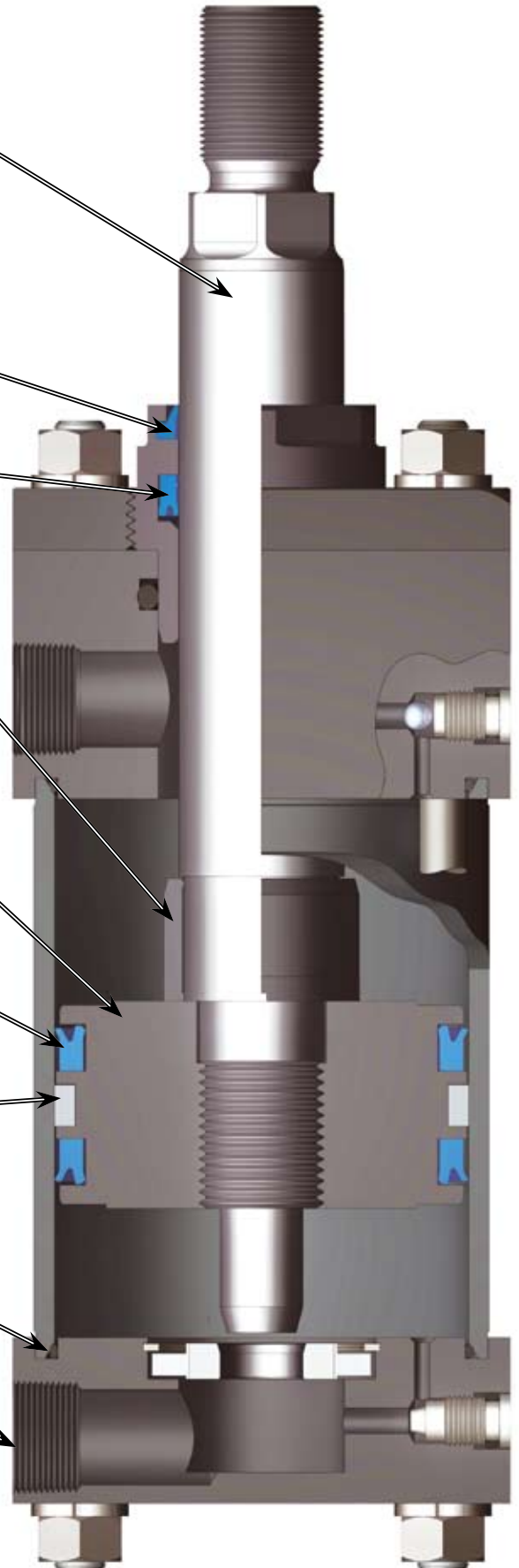

*All Blue seals can withstand most chemical washdown, No Fluorocarbon Required

ST5 SERIES

Medium Duty Hydraulic Cylinders

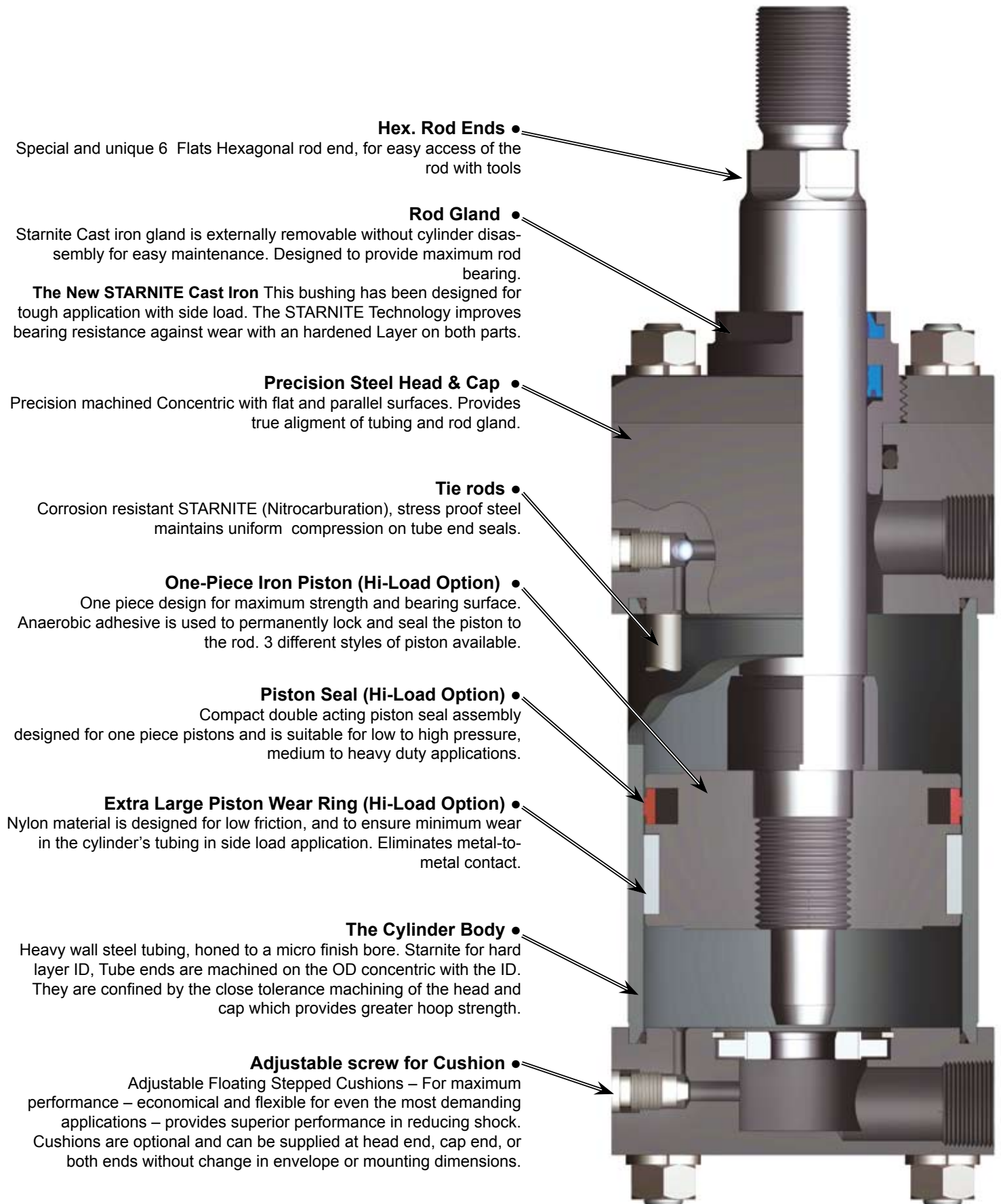

STARNITE

THE ANSWER TO WEAR, CORROSION AND FATIGUE PROBLEMS

The STARNITE process improves component properties.

High wear resistance, as well as excellent sliding and running properties, is obtained through STARNITE treatment. The service life of cylinders parts is extended. The finish created by the STARNITE process is a lustrous black.

During the process, which takes place at 1075°F, the metal surface is enriched with nitrogen and carbon. A two part nitride layer consisting of a monophase compound layer and a diffusion layer is formed. Total depth ranges from 0.008-0.040", depending on composition of the base material and treating time. Hardness in the compound layer ranges from approximately HV 700 (60 Rc) to about HV 1600 for high alloyed tools steel. As part of the salt-bath nitriding and QPQP (Quench-Polish & Quench & Polish) sequence, finish-machine parts are polished and chemically processed to produce a highly corrosion-resistant surface with a finish suitable for bearing or seal-type applications.

ENVIRONMENTALLY & ECONOMICALLY SAFE

Great concern exists in North America community regarding many critical materials because of North America's reliance on metals that are not native to this continent. Some 91% of the chromium used here is imported (9% balance from recycling). STARNITE process provides at least a partial solution to this problem and because it is not a plating or a coating but in the steel itself the process offers superior performance.

Corrosion resistance developed by the STARNITE technique out performs 12-micron (.0005 in.) chromium electroplating by ratio up to 20:1, and 20 micron (.0008 in.) nickel plating by a factor of 8:1.

Corrosion Resistance Evaluation
 Test conditions; Spool Shaft, ASTM B-117,
 (88h)test hours

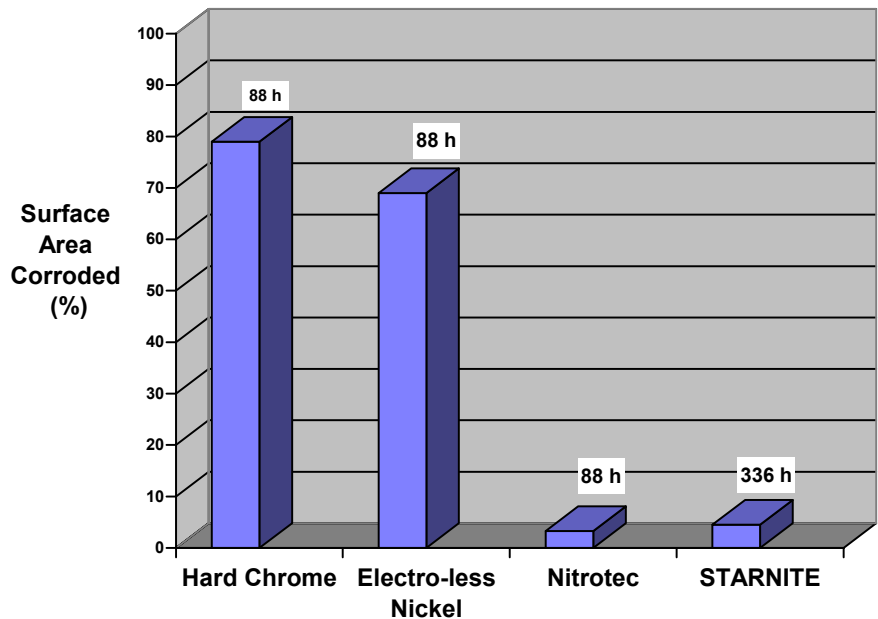

Chrome plated Vs STARNITE

Chromed plated cylinders

- Chrome plate can flake and blister.
- Flakes and slivers will destroy seals and glands.
- Loose chrome will cause massive leaking and rapid system failure.
- Chrome lacks dimensional uniformity.

STARNITE Process on cylinders

- Superior corrosion resistance.
- Improved wear resistance.
- Better lubrication retention.
- Dent resistance without induction hardening.
- Environmentally Friendly
- No surface pitting, flaking, or hydrogen embrittlement.
- INCREASED SERVICE LIFE.

ST5 SERIES

Medium Duty Hydraulic Cylinders













Standard Specifications

Medium Duty Service – ANSI/(NFPA) T3.6.7R2 - 1996
 Specifications and Mounting Dimension Standards
 Standard Construction: Square Head, Tie Rod Design
 Nominal Pressure : 1000 PSI Dependent on Bore Size*
 Standard Fluid: Hydraulic Oil
 Standard Temperature :-40°F to +230°F**
 Bore Sizes from 1.5” through 8”
 Piston Rod Diameter from 5/8” through 5-1/2”

Mounting Styles: 20 standard styles at various application ratings
 Strokes : Available in any practical stroke length
 Cushions : Optional at either end or both ends of stroke.
 Float Check at cap end.
 Rod Ends : Three Standard Choices – Specials to Order

See page 32, 33 and 34 For Spherical Bearing Mount Style ST5SB.

* See page 29 for recommended operating pressure.
 ** See page 35 Viton seals for higher temperature service.

Tie rods Head end ST5X3  NFPA MX3 page 6 & 20	Tie rods Cap end ST5X2  NFPA MX2 page 6 & 20	Tie rods Extended Both ends ST5X1  NFPA MX1 page 6 & 20	Head Rectangular Flange ST5F1  NFPA MF1 page 6
Head Square Flange ST5F5  NFPA MF5 page 8	Cap Rectangular Flange ST5F2  NFPA MF2 page 6	Cap Square Flange ST5F6  NFPA MF6 page 8	Side Lug ST5S2  NFPA MS2 page 10 & 22
Centerline Lugs ST5S3  NFPA MS3 page 10 & 22	Side Tap ST5S4  NFPA MS4 page 12 & 22	Side End Lugs ST5S7  NFPA MS7 page 12 & 24	Head Trunnion ST5T1  NFPA MT1 page 14 & 26
Cap Trunnion ST5T2  NFPA MT2 page 14 & 26	Intermediate Fixed Trunnion ST5T4  NFPA MT4 page 14 & 26	Cap Fixed Clevis ST5P1  NFPA MP1 page 16 & 24	Cap Detachable Clevis ST5P2  NFPA MP2 page 16
Head Rectangular Mount ST5E5  NFPA ME5 page 18	Head Square FLange ST5E3  NFPA ME3 page 20	Cap Square FLange ST5E4  NFPA ME4 page 20	Double Rod Cylinders ST5D  page 18

Tie Rod and Rectangular Flange Mountings
1 1/2 to 6" Bore Sizes

ST5 SERIES

Medium Duty Hydraulic Cylinders

Tie Rods Extended
Style ST5X3
(NFFPA Style MX3)

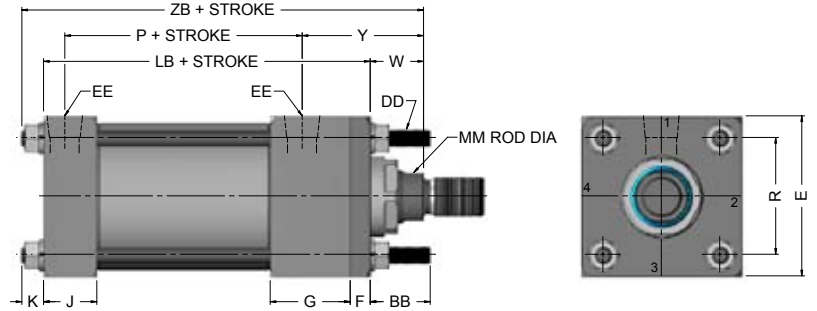

Style ST5X3 (NFFPA MX3) Head Tie Rods Extended, illustrated: Style ST5X2 (NFFPA MX2), Cap Tie Rods Extended; and Style ST5X1 (NFFPA MX1), Both Ends Tie Rods Extended are also available. All "T" styles can be dimensioned from Style ST5X3 drawing at right. Basic Mounting ST5X0 — NFFPA MX0 — no tie rods extended can be supplied upon request.

Head Rectangular Flange
Style ST5F1
(NFFPA Style MF1)



Bore Size	Max PSI — Push*				
	Rod Size				
	5/8	1	1 3/8	1 3/4	2
1 1/2	1400	850	-	-	-
2	850	1050	450	-	-
2 1/2	700	700	500	350	-
3 1/4	-	1300	1300	1000	900
4	-	900	900	900	900
5	-	600	800	600	700
6	-	-	700	700	700

Bore	Rod size			
	2 1/2	3	3 1/2	4
4	700	-	-	-
5	600	450	400	-
6	700	650	600	450

* Maximum pressure rating — push application.

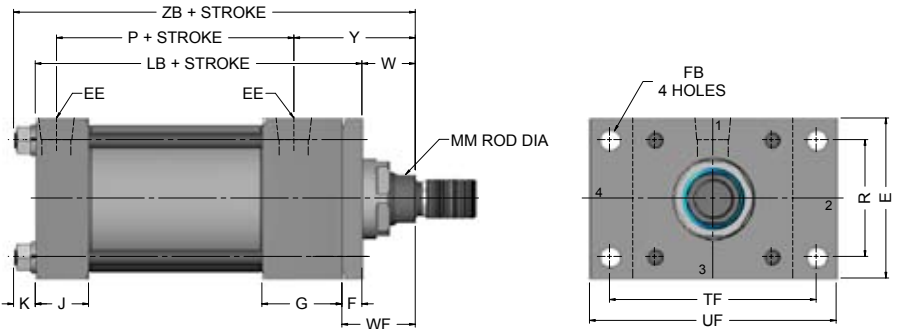

Cap Rectangular Flange
Style ST5F2
(NFFPA Style MF2)

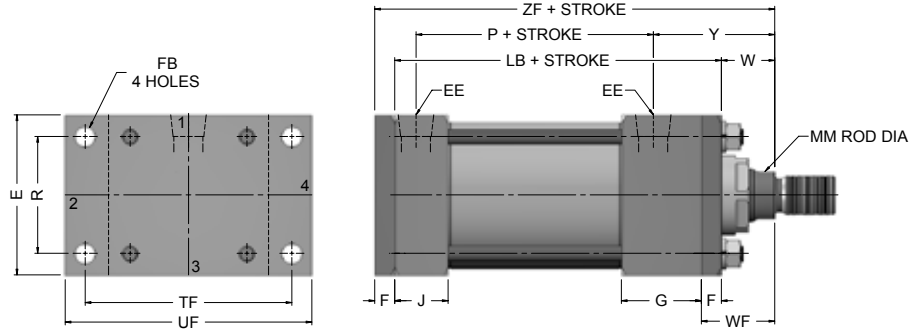

Rod End Dimensions—see table 2

Thread Style #2
(NFFPA Style SM)
Small Male

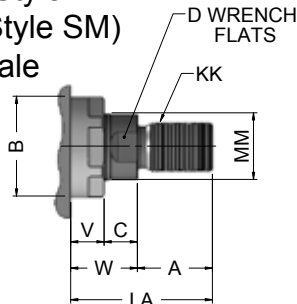

Thread Style #1
(NFFPA Style IM)
Intermediate Male

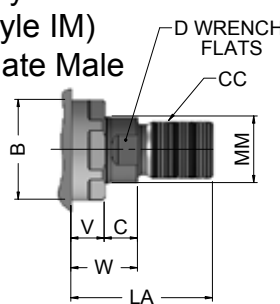

Thread Style #4
(NFFPA Style SF)
Small Female

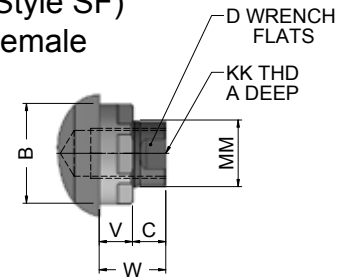

"Specials" Thread Style #X

To order, specify "Style #X" and give desired dimensions for CC or KK, A and LA. If otherwise special, furnish dimensional sketch.

A high strength rod end stud is supplied on thread style #2 through 1" diameter rods and on thread style #1 through 1" diameter rods. Larger sizes or special rod ends are cut threads. Style #2 rod ends are recommended where the workpiece is secured against the rod shoulder. When the workpiece is not shouldered, style 4 rod ends are recommended through 2" piston rod diameters and style #1 rod ends are recommended on larger diameters. Use style #4 for applications where female rod end threads are required. If rod end is not specified, style #2 will be supplied

ST5 SERIES

Medium Duty Hydraulic Cylinders

Tie Rod and
Rectangular Flange Mountings
1 1/2 to 6" Bore Sizes

Table 1—Envelope and Mounting Dimensions

BORE	AA	BB	DD	E	EE		F	FB	G	J	K	R	TF	UF	ADD STROKE	
					NPTF*	SAE**									LB	P
1 1/2	2.02	1	1/4-28	2	3/8	6	3/8	5/16	1 1/2	1	1/4	1.43	2 3/4	3 3/8	4	2 1/4
2	2.60	1 1/8	5/16-24	2 1/2	3/8	6	3/8	3/8	1 1/2	1	5/16	1.84	3 3/8	4 1/8	4	2 1/4
2 1/2	3.10	1 1/8	5/16-24	3	3/8	6	3/8	3/8	1 1/2	1	5/16	2.19	3 7/8	4 5/8	4 1/8	2 3/8
3 1/4	3.90	1 3/8	3/8-16	3 3/4	1/2	10	5/8	7/16	1 3/4	1 1/4	3/8	2.76	4 11/16	5 1/2	4 7/8	2 5/8
4	4.70	1 3/8	3/8-16	4 1/2	1/2	10	5/8	7/16	1 3/4	1 1/4	3/8	3.32	5 7/16	6 1/4	4 7/8	2 5/8
5	5.80	1 13/16	1/2-20	5 1/2	1/2	10	5/8	9/16	1 3/4	1 1/4	7/16	4.10	6 5/8	7 5/8	5 1/8	2 7/8
6	6.90	1 13/16	1/2-20	6 1/2	3/4	12	3/4	9/16	2	1 1/2	7/16	4.88	7 5/8	8 5/8	5 3/4	3 1/8

*NPTF ports will be furnished as standard unless SAE straight thread ports are specified.
** SAE straight thread ports are indicated by port number.

Table 2—Rod Dimensions

BORE	ROD SIZE	Thread Style		Rod Extensions and pilot dimensions								Add Stroke					
		STYLE #1	STYLE #2 & #4 KK	A	±.001 B	C	D	LA	NA	V	W	WF	Y	XF	ZB	ZF	
1 1/2	std	5/8	1/2-20	7/16-20	3/4	1.123	3/8	1/2	1 3/8	9/16	1/4	5/8	1	1 15/16	4 5/8	4 7/8	5
	1	7/8-14	3/4-16	1 1/8	1.498	1/2	7/8	2 1/8	15/16	1/2	1	1 3/8	2 5/16	5	5 1/4	5 3/8	
2	std	5/8	1/2-20	7/16-20	3/4	1.123	3/8	1/2	1 3/8	9/16	1/4	5/8	1	1 15/16	4 5/8	4 15/16	5
	1	7/8-14	3/4-16	1 1/8	1.498	1/2	7/8	2 1/8	15/16	1/2	1	1 3/8	2 5/16	5	5 5/16	5 3/8	
	1 3/8	1 1/4-12	1-14	1 5/8	1.998	5/8	1 1/8	2 7/8	1 5/16	5/8	1 1/4	1 5/8	2 9/16	5 1/4	5 9/16	5 5/8	
2.5		5/8	1/2-20	7/16-20	3/4	1.123	3/8	1/2	1 3/8	9/16	1/4	5/8	1	1 15/16	4 3/4	5 1/16	5 1/8
	std	1	7/8-14	3/4-16	1 1/8	1.498	1/2	7/8	2 1/8	15/16	1/2	1	1 3/8	2 5/16	5 1/8	5 7/16	5 1/2
	1 3/8	1 1/4-12	1-14	1 5/8	1.998	5/8	1 1/8	2 7/8	1 5/16	5/8	1 1/4	1 5/8	2 9/16	5 3/8	5 11/16	5 3/4	
	1 3/4	1 1/2-12	1 1/4-12	2	2.373	3/4	1 1/2	3 1/2	1 11/16	3/4	1 1/2	1 7/8	2 13/16	5 5/8	5 15/16	6	
3.25	std	1	7/8-14	3/4-16	1 1/8	1.498	1/2	7/8	1 7/8	15/16	1/4	5/8	1	1 15/16	4 3/4	5 1/16	5 1/8
	1 3/8	1 1/4-12	1-14	1 5/8	1.998	5/8	1 1/8	2 5/8	1 5/16	3/8	1	1 5/8	2 11/16	5 7/8	5 1/4	6 1/2	
	1 3/4	1 1/2-12	1 1/4-12	2	2.373	3/4	1 1/2	3 1/4	1 11/16	1/2	1 1/4	1 7/8	2 15/16	6 1/8	6 1/2	6 3/4	
	2	1 3/4-12	1 1/2-12	2 1/4	2.623	7/8	1 11/16	3 5/8	1 15/16	1/2	1 3/8	2	3 1/16	6 1/4	6 5/8	6 7/8	
4		1	7/8-14	3/4-16	1 1/8	1.498	1/2	7/8	1 7/8	15/16	1/4	5/8	1	1 15/16	4 3/4	5 1/16	5 1/8
	std	1 3/8	1 1/4-12	1-14	1 5/8	1.998	5/8	1 1/8	2 5/8	1 5/16	3/8	1	1 5/8	2 11/16	5 7/8	5 1/4	6 1/2
	1 3/4	1 1/2-12	1 1/4-12	2	2.373	3/4	1 1/2	3 1/4	1 11/16	1/2	1 1/4	1 7/8	2 15/16	6 1/8	6 1/2	6 3/4	
	2	1 3/4-12	1 1/2-12	2 1/4	2.623	7/8	1 11/16	3 5/8	1 15/16	1/2	1 3/8	2	3 1/16	6 1/4	6 5/8	6 7/8	
	2 1/2	2 1/4-12	1 7/8-12	3	3.123	1	2 1/16	4 5/8	2 3/8	5/8	1 5/8	2 1/4	3 5/16	6 1/2	6 7/8	7 1/8	
		2 1/2	2 1/4-12	1 7/8-12	3	3.123	1	2 1/16	4 5/8	2 3/8	5/8	1 5/8	2 1/4	3 5/16	6 1/2	6 7/8	7 1/8
5		1	7/8-14	3/4-16	1 1/8	1.498	1/2	7/8	1 7/8	15/16	1/4	3/4	1 3/8	2 7/16	5 7/8	6 5/16	6 1/2
	1 3/8	1 1/4-12	1-14	1 5/8	1.998	5/8	1 1/8	2 5/8	1 5/16	3/8	1	1 5/8	2 11/16	6 1/8	6 9/16	6 3/4	
	std	1 3/4	1 1/2-12	1 1/4-12	2	2.373	3/4	1 1/2	3 1/4	1 11/16	1/2	1 1/4	1 7/8	2 15/16	6 3/8	6 13/16	7
	2	1 3/4-12	1 1/2-12	2 1/4	2.623	7/8	1 11/16	3 5/8	1 15/16	1/2	1 3/8	2	3 1/16	6 1/2	6 15/16	7 1/8	
	2 1/2	2 1/4-12	1 7/8-12	3	3.123	1	2 1/16	4 5/8	2 3/8	5/8	1 5/8	2 1/4	3 5/16	6 3/4	7 3/16	7 3/8	
	3	2 3/4-12	2 1/4-12	3 1/2	3.748	1	2 5/8	5 1/8	2 7/8	5/8	1 5/8	2 1/4	3 5/16	6 3/4	7 3/16	7 3/8	
	3 1/2	3 1/4-12	2 1/2-12	3 1/2	4.248	1	3	5 1/8	3 3/8	5/8	1 5/8	2 1/4	3 5/16	6 3/4	7 3/16	7 3/8	
6		1 3/8	1 1/4-12	1-14	1 5/8	1.998	5/8	1 1/8	2 1/2	1 5/16	1/4	7/8	1 5/8	2 11/16	6 5/8	7 1/16	7 3/8
	std	1 3/4	1 1/2-12	1 1/4-12	2	2.373	3/4	1 1/2	3 1/8	1 11/16	3/8	1 1/8	1 7/8	3 1/16	6 7/8	7 5/16	7 5/8
	2	1 3/4-12	1 1/2-12	2 1/4	2.623	7/8	1 11/16	3 1/2	1 15/16	3/8	1 1/4	2	3 1/16	7	7 7/16	7 3/4	
	2 1/2	2 1/4-12	1 7/8-12	3	3.123	1	2 1/16	4 1/2	2 3/8	1/2	1 1/2	2 1/4	3 7/16	7 1/4	7 11/16	8	
	3	2 3/4-12	2 1/4-12	3 1/2	3.748	1	2 5/8	5	2 7/8	1/2	1 1/2	2 1/4	3 7/16	7 1/4	7 11/16	8	
	3 1/2	3 1/4-12	2 1/2-12	3 1/2	4.248	1	3	5	3 3/8	1/2	1 1/2	2 1/4	3 7/16	7 1/4	7 11/16	8	
	4	3 3/4-12	3-12	4	4.748	1	3 3/8	5 1/2	3 7/8	1/2	1 1/2	2 1/4	3 7/16	7 1/4	7 11/16	8	

Table 3—Envelope and Mounting Dimensions

Square Flange Mountings
1 1/2 to 6" Bore Sizes

ST5 SERIES

Medium Duty Hydraulic Cylinders

Head Square Flange
Style ST5F5
(NFPA Style MF5)

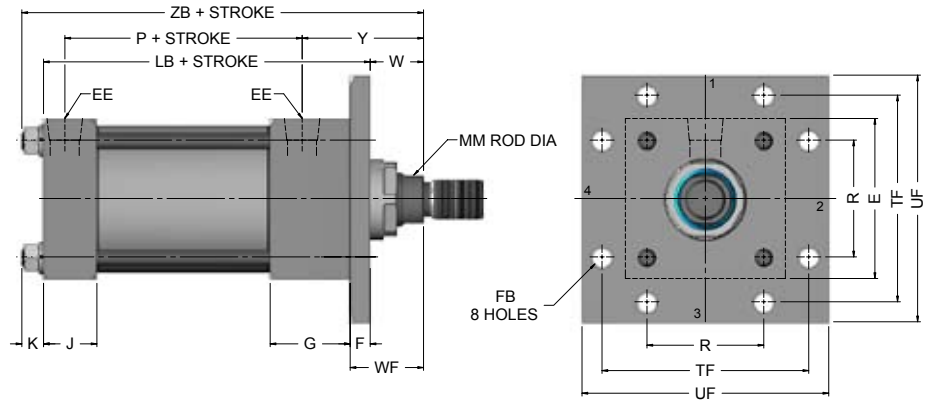
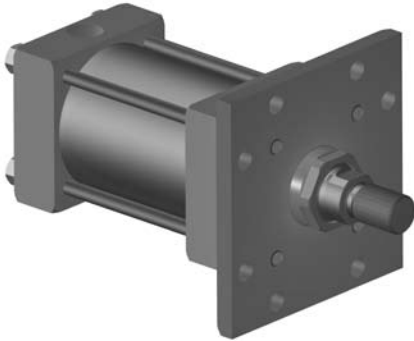

Cap Square Flange
Style ST5F6
(NFPA Style MF6)

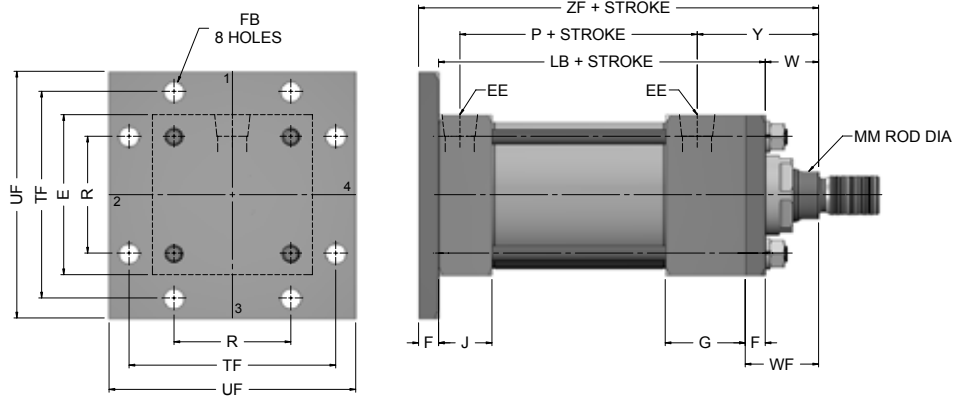
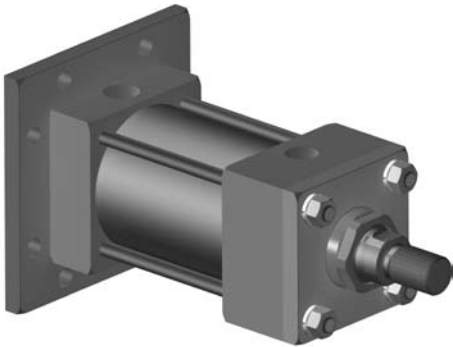

Rod End Dimensions—see table 2

Thread Style #2
(NFPA Style SM)
Small Male

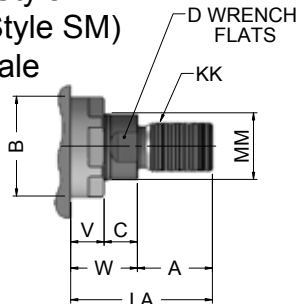

Thread Style #1
(NFPA Style IM)
Intermediate Male

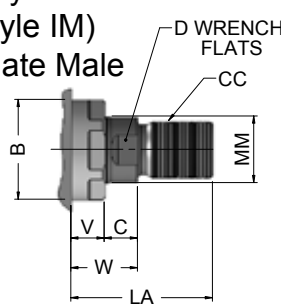

Thread Style #4
(NFPA Style SF)
Small Female

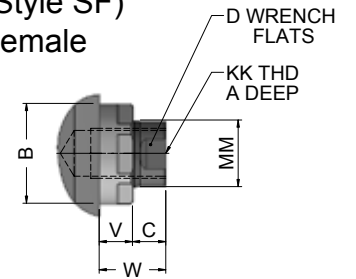

“Specials” Thread Style #X

To order, specify “Style #X” and give desired dimensions for CC or KK, A and LA. If otherwise special, furnish dimensional sketch.

A high strength rod end stud is supplied on thread style #2 through 1" diameter rods and on thread style #1 through 1" diameter rods. Larger sizes or special rod ends are cut threads. Style #2 rod ends are recommended where the workpiece is secured against the rod shoulder. When the workpiece is not shouldered, style 4 rod ends are recommended through 2" piston rod diameters and style #1 rod ends are recommended on larger diameters. Use style #4 for applications where female rod end threads are required. If rod end is not specified, style #2 will be supplied

ST5 SERIES

Medium Duty Hydraulic Cylinders

Square Flange Mountings
1 1/2 to 6" Bore Sizes

Table 1—Envelope and Mounting Dimensions

BORE	AA	BB	DD	E	EE		F	FB	G	J	K	R	TF	UF	ADD STROKE	
					NPTF*	SAE**									LB	P
1 1/2	2.02	1	1/4-28	2	3/8	6	3/8	5/16	1 1/2	1	1/4	1.43	2 3/4	3 3/8	4	2 1/4
2	2.60	1 1/8	5/16-24	2 1/2	3/8	6	3/8	3/8	1 1/2	1	5/16	1.84	3 3/8	4 1/8	4	2 1/4
2 1/2	3.10	1 1/8	5/16-24	3	3/8	6	3/8	3/8	1 1/2	1	5/16	2.19	3 7/8	4 5/8	4 1/8	2 3/8
3 1/4	3.90	1 3/8	3/8-16	3 3/4	1/2	10	5/8	7/16	1 3/4	1 1/4	3/8	2.76	4 11/16	5 1/2	4 7/8	2 5/8
4	4.70	1 3/8	3/8-16	4 1/2	1/2	10	5/8	7/16	1 3/4	1 1/4	3/8	3.32	5 7/16	6 1/4	4 7/8	2 5/8
5	5.80	1 13/16	1/2-20	5 1/2	1/2	10	5/8	9/16	1 3/4	1 1/4	7/16	4.10	6 5/8	7 5/8	5 1/8	2 7/8
6	6.90	1 13/16	1/2-20	6 1/2	3/4	12	3/4	9/16	2	1 1/2	7/16	4.88	7 5/8	8 5/8	5 3/4	3 1/8

*NPTF ports will be furnished as standard unless SAE straight thread ports are specified.
** SAE straight thread ports are indicated by port number.

Table 2—Rod Dimensions

BORE	ROD SIZE	Thread Style		Rod Extensions and pilot dimensions									Add Stroke				
		STYLE #1	STYLE #2 & #4 KK	A	±0.01 B	C	D	LA	NA	V	W	WF	Y	XF	ZB	ZF	
1 1/2	std	5/8	1/2-20	7/16-20	3/4	1.123	3/8	1/2	1 3/8	9/16	1/4	5/8	1	1 15/16	4 5/8	4 7/8	5
	1	7/8-14	3/4-16	1 1/8	1.498	1/2	7/8	2 1/8	15/16	1/2	1	1 3/8	2 5/16	5	5 1/4	5 3/8	
2	std	5/8	1/2-20	7/16-20	3/4	1.123	3/8	1/2	1 3/8	9/16	1/4	5/8	1	1 15/16	4 5/8	4 15/16	5
	1	7/8-14	3/4-16	1 1/8	1.498	1/2	7/8	2 1/8	15/16	1/2	1	1 3/8	2 5/16	5	5 5/16	5 3/8	
	1 3/8	1 1/4-12	1-14	1 5/8	1.998	5/8	1 1/8	2 7/8	1 5/16	5/8	1 1/4	1 5/8	2 9/16	5 1/4	5 9/16	5 5/8	
2.5		5/8	1/2-20	7/16-20	3/4	1.123	3/8	1/2	1 3/8	9/16	1/4	5/8	1	1 15/16	4 3/4	5 1/16	5 1/8
	std	1	7/8-14	3/4-16	1 1/8	1.498	1/2	7/8	2 1/8	15/16	1/2	1	1 3/8	2 5/16	5 1/8	5 7/16	5 1/2
	1 3/8	1 1/4-12	1-14	1 5/8	1.998	5/8	1 1/8	2 7/8	1 5/16	5/8	1 1/4	1 5/8	2 9/16	5 3/8	5 11/16	5 3/4	
	1 3/4	1 1/2-12	1 1/4-12	2	2.373	3/4	1 1/2	3 1/2	1 11/16	3/4	1 1/2	1 7/8	2 13/16	5 5/8	5 15/16	6	
3.25	std	1	7/8-14	3/4-16	1 1/8	1.498	1/2	7/8	1 7/8	15/16	1/4	5/8	1	1 15/16	4 3/4	5 1/16	5 1/8
	1 3/8	1 1/4-12	1-14	1 5/8	1.998	5/8	1 1/8	2 5/8	1 5/16	3/8	1	1 5/8	2 11/16	5 7/8	5 1/4	6 1/2	
	1 3/4	1 1/2-12	1 1/4-12	2	2.373	3/4	1 1/2	3 1/4	1 11/16	1/2	1 1/4	1 7/8	2 15/16	6 1/8	6 1/2	6 3/4	
	2	1 3/4-12	1 1/2-12	2 1/4	2.623	7/8	1 11/16	3 5/8	1 15/16	1/2	1 3/8	2	3 1/16	6 1/4	6 5/8	6 7/8	
4		1	7/8-14	3/4-16	1 1/8	1.498	1/2	7/8	1 7/8	15/16	1/4	5/8	1	1 15/16	4 3/4	5 1/16	5 1/8
	std	1 3/8	1 1/4-12	1-14	1 5/8	1.998	5/8	1 1/8	2 5/8	1 5/16	3/8	1	1 5/8	2 11/16	5 7/8	5 1/4	6 1/2
	1 3/4	1 1/2-12	1 1/4-12	2	2.373	3/4	1 1/2	3 1/4	1 11/16	1/2	1 1/4	1 7/8	2 15/16	6 1/8	6 1/2	6 3/4	
	2	1 3/4-12	1 1/2-12	2 1/4	2.623	7/8	1 11/16	3 5/8	1 15/16	1/2	1 3/8	2	3 1/16	6 1/4	6 5/8	6 7/8	
	2 1/2	2 1/4-12	1 7/8-12	3	3.123	1	2 1/16	4 5/8	2 3/8	5/8	1 5/8	2 1/4	3 5/16	6 1/2	6 7/8	7 1/8	
5		1	7/8-14	3/4-16	1 1/8	1.498	1/2	7/8	1 7/8	15/16	1/4	3/4	1 3/8	2 7/16	5 7/8	6 5/16	6 1/2
	1 3/8	1 1/4-12	1-14	1 5/8	1.998	5/8	1 1/8	2 5/8	1 5/16	3/8	1	1 5/8	2 11/16	6 1/8	6 9/16	6 3/4	
	std	1 3/4	1 1/2-12	1 1/4-12	2	2.373	3/4	1 1/2	3 1/4	1 11/16	1/2	1 1/4	1 7/8	2 15/16	6 3/8	6 13/16	7
	2	1 3/4-12	1 1/2-12	2 1/4	2.623	7/8	1 11/16	3 5/8	1 15/16	1/2	1 3/8	2	3 1/16	6 1/2	6 15/16	7 1/8	
	2 1/2	2 1/4-12	1 7/8-12	3	3.123	1	2 1/16	4 5/8	2 3/8	5/8	1 5/8	2 1/4	3 5/16	6 3/4	7 3/16	7 3/8	
	3	2 3/4-12	2 1/4-12	3 1/2	3.748	1	2 5/8	5 1/8	2 7/8	5/8	1 5/8	2 1/4	3 5/16	6 3/4	7 3/16	7 3/8	
	3 1/2	3 1/4-12	2 1/2-12	3 1/2	4.248	1	3	5 1/8	3 3/8	5/8	1 5/8	2 1/4	3 5/16	6 3/4	7 3/16	7 3/8	
6		1 3/8	1 1/4-12	1-14	1 5/8	1.998	5/8	1 1/8	2 1/2	1 5/16	1/4	7/8	1 5/8	2 11/16	6 5/8	7 1/16	7 3/8
	std	1 3/4	1 1/2-12	1 1/4-12	2	2.373	3/4	1 1/2	3 1/8	1 11/16	3/8	1 1/8	1 7/8	3 1/16	6 7/8	7 5/16	7 5/8
	2	1 3/4-12	1 1/2-12	2 1/4	2.623	7/8	1 11/16	3 1/2	1 15/16	3/8	1 1/4	2	3 1/16	7	7 7/16	7 3/4	
	2 1/2	2 1/4-12	1 7/8-12	3	3.123	1	2 1/16	4 1/2	2 3/8	1/2	1 1/2	2 1/4	3 7/16	7 1/4	7 11/16	8	
	3	2 3/4-12	2 1/4-12	3 1/2	3.748	1	2 5/8	5	2 7/8	1/2	1 1/2	2 1/4	3 7/16	7 1/4	7 11/16	8	
	3 1/2	3 1/4-12	2 1/2-12	3 1/2	4.248	1	3	5	3 3/8	1/2	1 1/2	2 1/4	3 7/16	7 1/4	7 11/16	8	
	4	3 3/4-12	3-12	4	4.748	1	3 3/8	5 1/2	3 7/8	1/2	1 1/2	2 1/4	3 7/16	7 1/4	7 11/16	8	

Table 3—Envelope and Mounting Dimensions

Side Lugs and
Centerline Lugs
1 1/2 to 6" Bore Sizes

ST5 SERIES

Medium Duty Hydraulic Cylinders

Side Lug
Style ST5S2
(NFPA Style MS2)

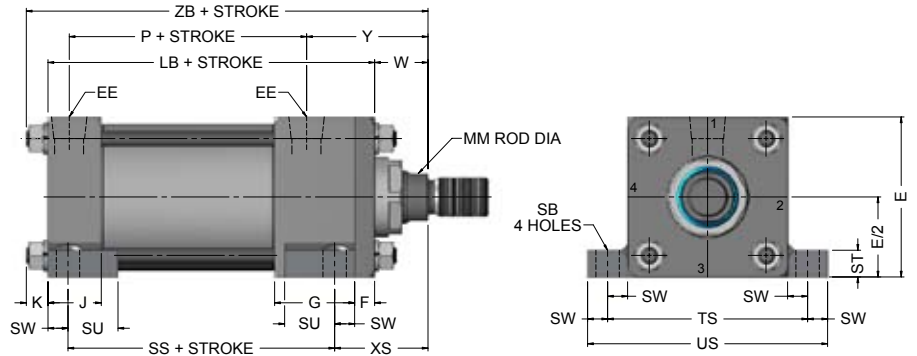

Centerline Lugs
Style ST5S3
(NFPA Style MS3)

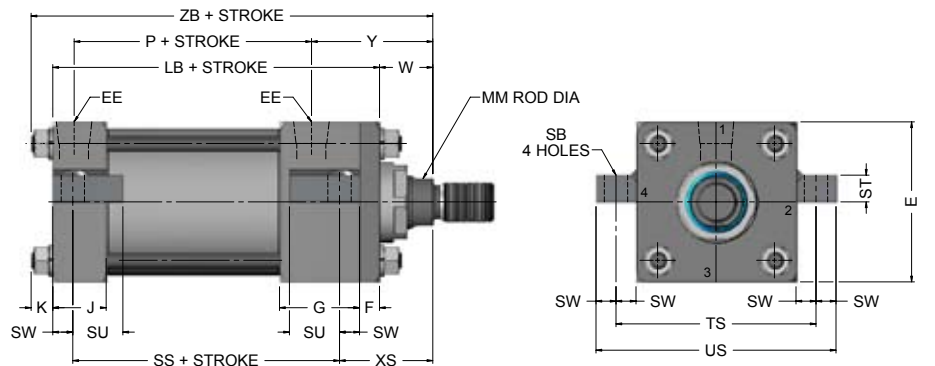

Rod End Dimensions—see table 2

Thread Style #2
(NFPA Style SM)
Small Male

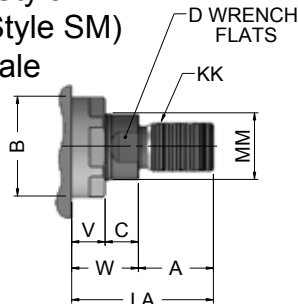

Thread Style #1
(NFPA Style IM)
Intermediate Male

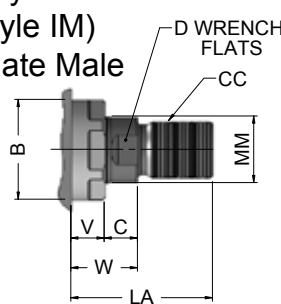

Thread Style #4
(NFPA Style SF)
Small Female

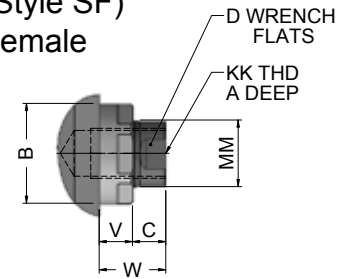

“Specials” Thread Style #X

To order, specify “Style #X” and give desired dimensions for CC or KK, A and LA. If otherwise special, furnish dimensional sketch.

A high strength rod end stud is supplied on thread style #2 through 1" diameter rods and on thread style #1 through 1" diameter rods. Larger sizes or special rod ends are cut threads. Style #2 rod ends are recommended where the workpiece is secured against the rod shoulder. When the workpiece is not shouldered, style 4 rod ends are recommended through 2" piston rod diameters and style #1 rod ends are recommended on larger diameters. Use style #4 for applications where female rod end threads are required. If rod end is not specified, style #2 will be supplied

ST5 SERIES

Medium Duty Hydraulic Cylinders

Side Lugs and
Centerline Lugs
1 1/2 to 6" Bore Sizes

Table 1—Envelope and Mounting Dimensions

BORE	E	EE		F	G	J	K	SB	ST	SU	SW	TS	US	ADD STROKE		
		NPTF*	SAE**											LB	P	SS
1 1/2	2	3/8	6	3/8	1 1/2	1	1/4	7/16	1/2	15/16	3/8	2 3/4	3 1/2	4	2 1/4	2 7/8
2	2 1/2	3/8	6	3/8	1 1/2	1	5/16	7/16	1/2	15/16	3/8	3 1/4	4	4	2 1/4	2 7/8
2 1/2	3	3/8	6	3/8	1 1/2	1	5/16	7/16	1/2	15/16	3/8	3 3/4	4 1/2	4 1/8	2 3/8	3
3 1/4	3 3/4	1/2	10	5/8	1 3/4	1 1/4	3/8	1/16	3/4	1 1/4	1/2	4 3/4	5 3/4	4 7/8	2 5/8	3 1/4
4	4 1/2	1/2	10	5/8	1 3/4	1 1/4	3/8	9/16	3/4	1 1/4	1/2	5 1/2	6 1/2	4 7/8	2 5/8	3 1/4
5	5 1/2	1/2	10	5/8	1 3/4	1 1/4	7/16	13/16	1	1 9/16	11/16	6 7/8	8 1/4	5 1/8	2 7/8	3 1/8
6	6 1/2	3/4	12	3/4	2	1 1/2	7/16	13/16	1	1 9/16	11/16	7 7/8	9 1/4	5 3/4	3 1/8	3 5/8

*NPTF ports will be furnished as standard unless SAE straight thread ports are specified.

** SAE straight thread ports are indicated by port number.

Table 2—Rod Dimensions

BORE	ROD SIZE	Thread Style		Rod Extensions and pilot dimensions									XS	Y	Add Stroke ZB
		STYLE #1	STYLE #2 & #4 KK	A	±.001 B	C	D	LA	NA	V	W				
1 1/2	std	5/8	1/2-20	7/16-20	3/4	1.123	3/8	1/2	1 3/8	9/16	1/4	5/8	1 3/8	1 15/16	4 7/8
	1	7/8-14	3/4-16	1 1/8	1.498	1/2	7/8	2 1/8	15/16	1/2	1	1 3/4	2 5/16	5 1/4	
2	std	5/8	1/2-20	7/16-20	3/4	1.123	3/8	1/2	1 3/8	9/16	1/4	5/8	1 3/8	1 15/16	4 15/16
	1	7/8-14	3/4-16	1 1/8	1.498	1/2	7/8	2 1/8	15/16	1/2	1	1 3/4	2 5/16	5 5/16	
	1 3/8	1 1/4-12	1-14	1 5/8	1.998	5/8	1 1/8	2 7/8	1 5/16	5/8	1 1/4	2	2 9/16	5 7/16	
2.5		5/8	1/2-20	7/16-20	3/4	1.123	3/8	1/2	1 3/8	9/16	1/4	5/8	1 3/8	1 15/16	5 1/16
	std	1	7/8-14	3/4-16	1 1/8	1.498	1/2	7/8	2 1/8	15/16	1/2	1	1 3/4	2 5/16	5 7/16
	1 3/8	1 1/4-12	1-14	1 5/8	1.998	5/8	1 1/8	2 7/8	1 5/16	5/8	1 1/4	2	2 9/16	5 11/16	
	1 3/4	1 1/2-12	1 1/4-12	2	2.373	3/4	1 1/2	3 1/2	1 11/16	3/4	1 1/2	2 1/4	2 13/16	5 15/16	
3.25	std	1	7/8-14	3/4-16	1 1/8	1.498	1/2	7/8	1 7/8	15/16	1/4	5/8	1 7/8	1 15/16	6
	1 3/8	1 1/4-12	1-14	1 5/8	1.998	5/8	1 1/8	2 5/8	1 5/16	3/8	1	2 1/8	2 11/16	6 1/4	
	1 3/4	1 1/2-12	1 1/4-12	2	2.373	3/4	1 1/2	3 1/4	1 11/16	1/2	1 1/4	2 3/8	2 15/16	6 1/2	
	2	1 3/4-12	1 1/2-12	2 1/4	2.623	7/8	1 11/16	3 5/8	1 15/16	1/2	1 3/8	2 1/2	3 1/16	6 5/8	
4		1	7/8-14	3/4-16	1 1/8	1.498	1/2	7/8	1 7/8	15/16	1/4	5/8	1 7/8	1 15/16	6
	std	1 3/8	1 1/4-12	1-14	1 5/8	1.998	5/8	1 1/8	2 5/8	1 5/16	3/8	1	2 1/8	2 11/16	6 1/4
	1 3/4	1 1/2-12	1 1/4-12	2	2.373	3/4	1 1/2	3 1/4	1 11/16	1/2	1 1/4	2 3/8	2 15/16	6 1/2	
	2	1 3/4-12	1 1/2-12	2 1/4	2.623	7/8	1 11/16	3 5/8	1 15/16	1/2	1 3/8	2 1/2	3 1/16	6 5/8	
	2 1/2	2 1/4-12	1 7/8-12	3	3.123	1	2 1/16	4 5/8	2 3/8	5/8	1 5/8	2 3/4	3 5/16	6 7/8	
5		1	7/8-14	3/4-16	1 1/8	1.498	1/2	7/8	1 7/8	15/16	1/4	3/4	2 1/16	2 7/16	6 5/16
	1 3/8	1 1/4-12	1-14	1 5/8	1.998	5/8	1 1/8	2 5/8	1 5/16	3/8	1	2 5/16	2 11/16	6 9/16	
	std	1 3/4	1 1/2-12	1 1/4-12	2	2.373	3/4	1 1/2	3 1/4	1 11/16	1/2	1 1/4	2 9/16	2 15/16	6 13/16
	2	1 3/4-12	1 1/2-12	2 1/4	2.623	7/8	1 11/16	3 5/8	1 15/16	1/2	1 3/8	2 11/16	3 1/16	6 15/16	
	2 1/2	2 1/4-12	1 7/8-12	3	3.123	1	2 1/16	4 5/8	2 3/8	5/8	1 5/8	2 15/16	3 5/16	7 3/16	
	3	2 3/4-12	2 1/4-12	3 1/2	3.748	1	2 5/8	5 1/8	2 7/8	5/8	1 5/8	2 15/16	3 5/16	7 3/16	
	3 1/2	3 1/4-12	2 1/2-12	3 1/2	4.248	1	3	5 1/8	3 3/8	5/8	1 5/8	2 15/16	3 5/16	7 3/16	
6		1 3/8	1 1/4-12	1-14	1 5/8	1.998	5/8	1 1/8	2 1/2	1 5/16	1/4	7/8	2 5/16	2 11/16	7 1/16
	std	1 3/4	1 1/2-12	1 1/4-12	2	2.373	3/4	1 1/2	3 1/8	1 11/16	3/8	1 1/8	2 9/16	3 1/16	7 5/16
	2	1 3/4-12	1 1/2-12	2 1/4	2.623	7/8	1 11/16	3 1/2	1 15/16	3/8	1 1/4	2 11/16	3 1/16	7 7/16	
	2 1/2	2 1/4-12	1 7/8-12	3	3.123	1	2 1/16	4 1/2	2 3/8	1/2	1 1/2	2 15/16	3 7/16	7 11/16	
	3	2 3/4-12	2 1/4-12	3 1/2	3.748	1	2 5/8	5	2 7/8	1/2	1 1/2	2 15/16	3 7/16	7 11/16	
	3 1/2	3 1/4-12	2 1/2-12	3 1/2	4.248	1	3	5	3 3/8	1/2	1 1/2	2 15/16	3 7/16	7 11/16	
	4	3 3/4-12	3-12	4	4.748	1	3 3/8	5 1/2	3 7/8	1/2	1 1/2	2 15/16	3 7/16	7 11/16	

Table 3—Envelope and Mounting Dimensions

Side End Lugs and
Side Tapped Mountings
1 1/2 to 6" Bore Sizes

ST5 SERIES

Medium Duty Hydraulic Cylinders

Side Tapped
Style ST5S4
(NFFA Style MS4)

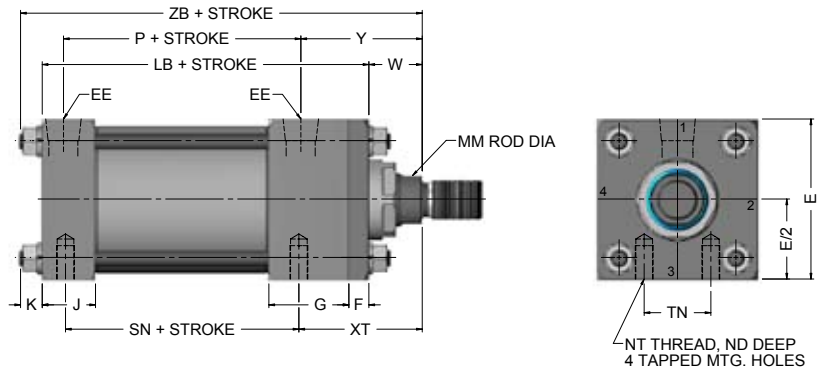

Side End Lug
Style ST5S7
(NFFA Style MS7)

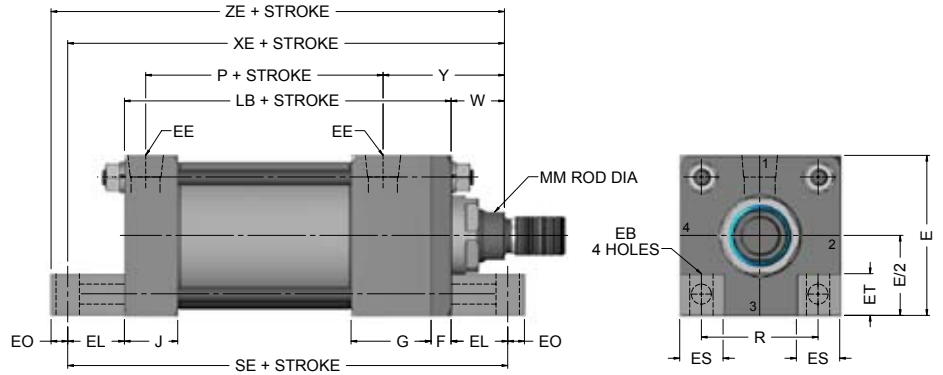

Rod End Dimensions—see table 2

Thread Style #2
(NFFA Style SM)
Small Male

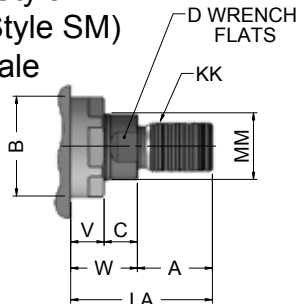

Thread Style #1
(NFFA Style IM)
Intermediate Male

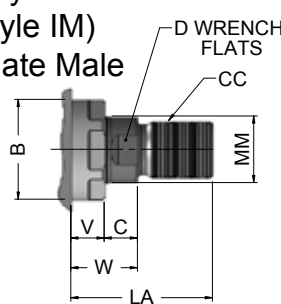

Thread Style #4
(NFFA Style SF)
Small Female

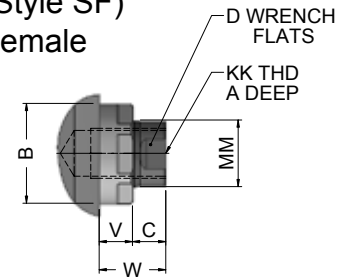

“Specials” Thread Style #X

To order, specify “Style #X” and give desired dimensions for CC or KK, A and LA. If otherwise special, furnish dimensional sketch.

A high strength rod end stud is supplied on thread style #2 through 1" diameter rods and on thread style #1 through 1" diameter rods. Larger sizes or special rod ends are cut threads. Style #2 rod ends are recommended where the workpiece is secured against the rod shoulder. When the workpiece is not shouldered, style #4 rod ends are recommended through 2" piston rod diameters and style #1 rod ends are recommended on larger diameters. Use style #4 for applications where female rod end threads are required. If rod end is not specified, style #2 will be supplied

ST5 SERIES

Medium Duty Hydraulic Cylinders

Side End Lugs and
Side Tapped Mountings
1 1/2 to 6" Bore Sizes

Table 1—Envelope and Mounting Dimensions

BORE	E	EB	EE		EL	EO	ES	ET	F	G	J	K	NT	TN	R	ADD STROKE			
			NPTF*	SAE**												LB	P	SE	SN
1 1/2	2	5/16	3/8	6	3/4	1/4	9/16	17/32	3/8	1 1/2	1	1/4	1/4-20	5/8	1.43	4	2 1/4	5 1/2	2 1/4
2	2 1/2	3/8	3/8	6	15/16	5/16	5/8	5/8	3/8	1 1/2	1	5/16	5/16-18	7/8	1.84	4	2 1/4	5 7/8	2 1/4
2 1/2	3	3/8	3/8	6	1 1/16	5/16	13/16	15/32	3/8	1 1/2	1	5/16	3/8-16	1 1/4	2.19	4 1/8	2 3/8	6 1/4	2 3/8
3 1/4	3 3/4	7/16	1/2	10	7/8	3/8	1	15/16	5/8	1 3/4	1 1/4	3/8	1/2-13	1 1/2	2.76	4 7/8	2 5/8	6 5/8	2 5/8
4	4 1/2	7/16	1/2	10	1	3/8	1 1/4	1 5/32	5/8	1 3/4	1 1/4	3/8	1/2-13	2 1/16	3.32	4 7/8	2 5/8	6 7/8	2 5/8
5	5 1/2	9/16	1/2	10	1 1/16	1/2	1 3/8	1 3/8	5/8	1 3/4	1 1/4	7/16	5/8-11	2 11/16	4.10	5 1/8	2 7/8	7 1/4	2 7/8
6	6 1/2	9/16	3/4	12	1	1/2	1 3/4	1 19/32	3/4	2	1 1/2	7/16	3/4-10	3 1/4	4.88	5 3/4	3 1/8	7 3/4	3 1/8

*NPTF ports will be furnished as standard unless SAE straight thread ports are specified.
** SAE straight thread ports are indicated by port number.

Table 2—Rod Dimensions

BORE	ROD SIZE	Thread Style		Rod Extensions and pilot dimensions									Add Stroke					
		STYLE #1	STYLE #2 & #4 KK	A	±.001 B	C	D	LA	NA	V	W	ND	XT	Y	XE	ZB	ZE	
1 1/2	std	5/8	1/2-20	7/16-20	3/4	1.123	3/8	1/2	1 3/8	9/16	1/4	5/8	3/16	1 15/16	1 15/16	5 3/8	4 7/8	5 5/8
	1	7/8-14	3/4-16	1 1/8	1.498	1/2	7/8	2 1/8	15/16	1/2	1	3/16	2 5/16	2 5/16	5 3/4	5 1/4	6	
2	std	5/8	1/2-20	7/16-20	3/4	1.123	3/8	1/2	1 3/8	9/16	1/4	5/8	11/32	1 15/16	1 15/16	5 9/16	4 15/16	5 7/8
	1	7/8-14	3/4-16	1 1/8	1.498	1/2	7/8	2 1/8	15/16	1/2	1	11/32	2 5/16	2 5/16	5 15/16	5 5/16	6 1/4	
	1 3/8	1 1/4-12	1-14	1 5/8	1.998	5/8	1 1/8	2 7/8	1 5/16	5/8	1 1/4	11/32	2 9/16	2 9/16	6 3/16	5 7/16	6 1/2	
2 1/2	std	5/8	1/2-20	7/16-20	3/4	1.123	3/8	1/2	1 3/8	9/16	1/4	5/8	7/16	1 15/16	1 15/16	5 13/16	5 1/16	6 1/8
	1	7/8-14	3/4-16	1 1/8	1.498	1/2	7/8	2 1/8	15/16	1/2	1	7/16	2 5/16	2 5/16	6 3/16	5 7/16	6 1/2	
	1 3/8	1 1/4-12	1-14	1 5/8	1.998	5/8	1 1/8	2 7/8	1 5/16	5/8	1 1/4	7/16	2 9/16	2 9/16	6 7/16	5 11/16	6 3/4	
	1 3/4	1 1/2-12	1 1/4-12	2	2.373	3/4	1 1/2	3 1/2	1 11/16	3/4	1 1/2	7/16	2 13/16	2 13/16	6 11/16	5 15/16	7	
3 1/4	std	1	7/8-14	3/4-16	1 1/8	1.498	1/2	7/8	1 7/8	15/16	1/4	5/8	1/2	1 15/16	1 15/16	6 1/2	6	6 7/8
	1 3/8	1 1/4-12	1-14	1 5/8	1.998	5/8	1 1/8	2 5/8	1 5/16	3/8	1	1/2	2 11/16	2 11/16	6 3/4	6 1/4	7 1/8	
	1 3/4	1 1/2-12	1 1/4-12	2	2.373	3/4	1 1/2	3 1/4	1 11/16	1/2	1 1/4	1/2	2 15/16	2 15/16	7	6 1/2	7 3/8	
	2	1 3/4-12	1 1/2-12	2 1/4	2.623	7/8	1 11/16	3 5/8	1 15/16	1/2	1 3/8	1/2	3 1/16	3 1/16	7 1/8	6 5/8	7 1/2	
4	1	7/8-14	3/4-16	1 1/8	1.498	1/2	7/8	1 7/8	15/16	1/4	5/8	5/8	1 15/16	1 15/16	6 5/8	6	7	
	std	1 3/8	1 1/4-12	1-14	1 5/8	1.998	5/8	1 1/8	2 5/8	1 5/16	3/8	1	5/8	2 11/16	2 11/16	6 7/8	6 1/4	7 1/4
	1 3/4	1 1/2-12	1 1/4-12	2	2.373	3/4	1 1/2	3 1/4	1 11/16	1/2	1 1/4	5/8	2 15/16	2 15/16	7 1/8	6 1/2	7 1/2	
	2	1 3/4-12	1 1/2-12	2 1/4	2.623	7/8	1 11/16	3 5/8	1 15/16	1/2	1 3/8	5/8	3 1/16	3 1/16	7 1/4	6 5/8	7 5/8	
	2 1/2	2 1/4-12	1 7/8-12	3	3.123	1	2 1/16	4 5/8	2 3/8	5/8	1 5/8	5/8	3 5/16	3 5/16	7 1/2	6 7/8	7 7/8	
	3	2 3/4-12	2 1/4-12	3 1/2	3.748	1	2 5/8	5 1/8	2 7/8	5/8	1 5/8	3/4	3 5/16	3 5/16	7 13/16	7 3/16	8 5/16	
5	1	7/8-14	3/4-16	1 1/8	1.498	1/2	7/8	1 7/8	15/16	1/4	3/4	3/4	2 7/16	2 7/16	6 15/16	6 5/16	7 7/16	
	1 3/8	1 1/4-12	1-14	1 5/8	1.998	5/8	1 1/8	2 5/8	1 5/16	3/8	1	3/4	2 11/16	2 11/16	7 3/16	6 9/16	7 11/16	
	std	1 3/4	1 1/2-12	1 1/4-12	2	2.373	3/4	1 1/2	3 1/4	1 11/16	1/2	1 1/4	3/4	2 15/16	2 15/16	7 7/16	6 13/16	7 15/16
	2	1 3/4-12	1 1/2-12	2 1/4	2.623	7/8	1 11/16	3 5/8	1 15/16	1/2	1 3/8	3/4	3 1/16	3 1/16	7 9/16	6 15/16	8 1/16	
	2 1/2	2 1/4-12	1 7/8-12	3	3.123	1	2 1/16	4 5/8	2 3/8	5/8	1 5/8	3/4	3 5/16	3 5/16	7 13/16	7 3/16	8 5/16	
	3	2 3/4-12	2 1/4-12	3 1/2	3.748	1	2 5/8	5 1/8	2 7/8	5/8	1 5/8	3/4	3 5/16	3 5/16	7 13/16	7 3/16	8 5/16	
	3 1/2	3 1/4-12	2 1/2-12	3 1/2	4.248	1	3	5 1/8	3 3/8	5/8	1 5/8	3/4	3 5/16	3 5/16	7 13/16	7 3/16	8 5/16	
6	1 3/8	1 1/4-12	1-14	1 5/8	1.998	5/8	1 1/8	2 1/2	1 5/16	1/4	7/8	7/8	2 11/16	2 11/16	7 5/8	7 1/16	8 1/8	
	std	1 3/4	1 1/2-12	1 1/4-12	2	2.373	3/4	1 1/2	3 1/8	1 11/16	3/8	1 1/8	7/8	3 1/16	3 1/16	7 7/8	7 5/16	8 3/8
	2	1 3/4-12	1 1/2-12	2 1/4	2.623	7/8	1 11/16	3 1/2	1 15/16	3/8	1 1/4	7/8	3 1/16	3 1/16	8	7 7/16	8 1/2	
	2 1/2	2 1/4-12	1 7/8-12	3	3.123	1	2 1/16	4 1/2	2 3/8	1/2	1 1/2	7/8	3 7/16	3 7/16	8 1/4	7 11/16	8 3/4	
	3	2 3/4-12	2 1/4-12	3 1/2	3.748	1	2 5/8	5	2 7/8	1/2	1 1/2	7/8	3 7/16	3 7/16	8 1/4	7 11/16	8 3/4	
	3 1/2	3 1/4-12	2 1/2-12	3 1/2	4.248	1	3	5	3 3/8	1/2	1 1/2	7/8	3 7/16	3 7/16	8 1/4	7 11/16	8 3/4	
	4	3 3/4-12	3-12	4	4.748	1	3 3/8	5 1/2	3 7/8	1/2	1 1/2	7/8	3 7/16	3 7/16	8 1/4	7 11/16	8 3/4	

Caution: When using mounting styles ST3S7, check clearance between mounting members and rod attachment or accessory. If necessary, specify longer rod extension to avoid interference with mounting members.

ST5 SERIES

Medium Duty Hydraulic Cylinders

Trunnion Mountings
1 1/2 to 6" Bore Sizes

Head Trunnion
Style ST5T1
(NFFPA Style MT1)

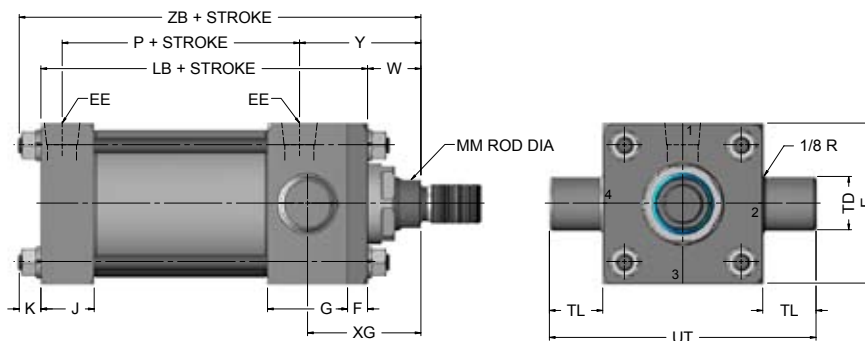

Cap Trunnion
Style ST5T2
(NFFPA Style MT2)

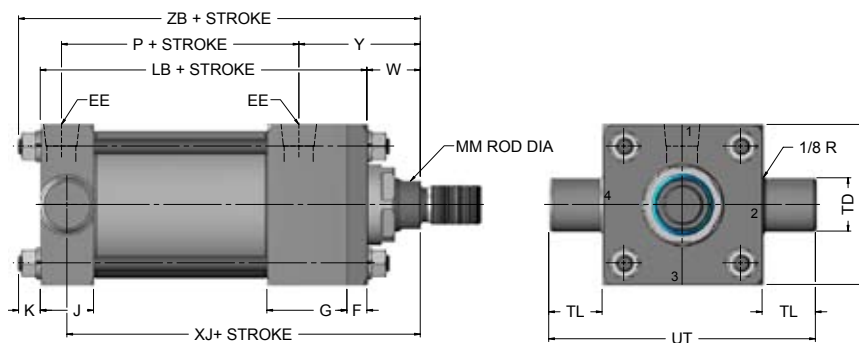

Intermediate Fixed Trunnion
Style ST5T4
(NFFPA Style MT4)

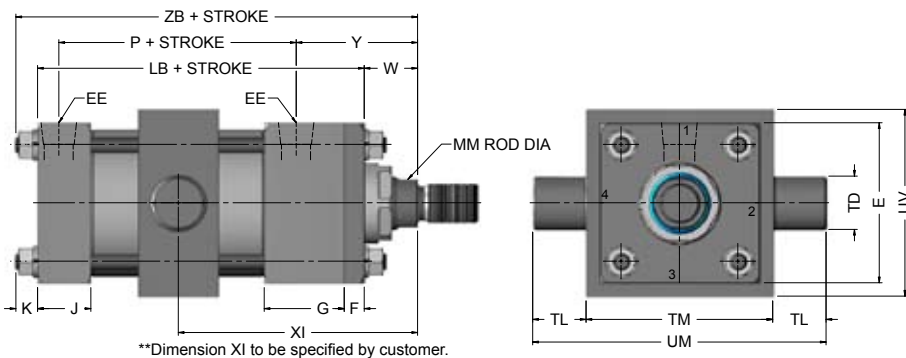
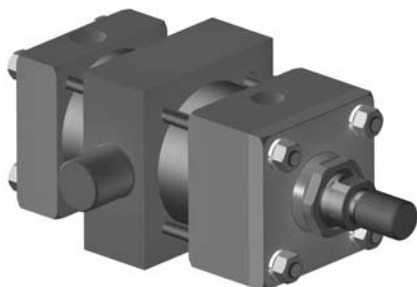

Rod End Dimensions—see table 2

Thread Style #2
(NFFPA Style SM)
Small Male

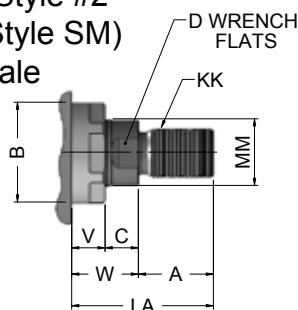

Thread Style #1
(NFFPA Style IM)
Intermediate Male

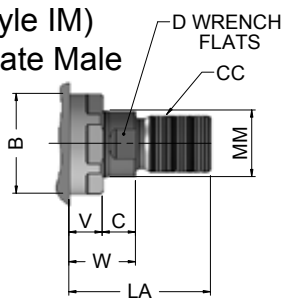

Thread Style #4
(NFFPA Style SF)
Small Female

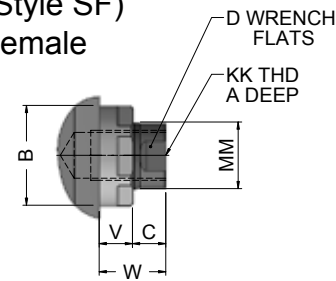

“Specials” Thread Style #X

To order, specify “Style #X” and give desired dimensions for CC or KK, A and LA. If otherwise special, furnish dimensional sketch.

A high strength rod end stud is supplied on thread style #2 through 1" diameter rods and on thread style #1 through 1" diameter rods. Larger sizes or special rod ends are cut threads. Style #2 rod ends are recommended where the workpiece is secured against the rod shoulder. When the workpiece is not shouldered, style 4 rod ends are recommended through 2" piston rod diameters and style #1 rod ends are recommended on larger diameters. Use style #4 for applications where female rod end threads are required. If rod end is not specified, style #2 will be supplied

ST5 SERIES

Medium Duty Hydraulic Cylinders

Trunnion Mountings
1 1/2 to 6" Bore Sizes

Table 1—Envelope and Mounting Dimensions

BORE	BD	E	EE		F	G	J	K	+.000 TD -.001	TL	TM	UM	UT	UV	ADD STROKE		MIN STROKE
			NPTF*	SAE**											LB	P	
1 1/2	1 1/4	2	3/8	6	3/8	1 1/2	1	1/4	1.000	1	2 1/2	4 1/2	4	2 1/2	4	2 1/4	1/4
2	1 1/2	2 1/2	3/8	6	3/8	1 1/2	1	5/16	1.000	1	3	5	4 1/2	3	4	2 1/4	1/2
2 1/2	1 1/2	3	3/8	6	3/8	1 1/2	1	5/16	1.000	1	3 1/2	5 1/2	5	3 1/2	4 1/8	2 3/8	3/8
3 1/4	2	3 3/4	1/2	10	5/8	1 3/4	1 1/4	3/8	1.000	1	4 1/2	6 1/2	5 3/4	4 1/4	4 7/8	2 5/8	7/8
4	2	4 1/2	1/2	10	5/8	1 3/4	1 1/4	3/8	1.000	1	5 1/4	7 1/4	6 1/2	5	4 7/8	2 5/8	7/8
5	2	5 1/2	1/2	10	5/8	1 3/4	1 1/4	7/16	1.000	1	6 1/4	8 1/4	7 1/2	6	5 1/8	2 7/8	5/8
6	2 1/2	6 1/2	3/4	12	3/4	2	1 1/2	7/16	1.375	1 3/8	7 5/8	10 3/8	9 1/4	7	5 3/4	3 1/8	1 1/8

*NPTF ports will be furnished as standard unless SAE straight thread ports are specified.

** SAE straight thread ports are indicated by port number.

Table 3—Envelope and Mounting Dimensions

Table 2—Rod Dimensions

BORE	ROD SIZE	Thread Style		Rod Extensions and pilot dimensions									Add Stroke			
		STYLE #1	STYLE #2 & #4 KK	A	±.001 B	C	D	LA	NA	V	W	XG	MIN** XI	Y	XJ	ZB
1 1/2	std 5/8	1/2-20	7/16-20	3/4	1.123	3/8	1/2	1 3/8	9/16	1/4	5/8	1 3/4	3 3/16	1 15/16	4 1/8	4 7/8
	1	7/8-14	3/4-16	1 1/8	1.498	1/2	7/8	2 1/8	15/16	1/2	1	2 1/8	3 9/16	2 5/16	4 1/2	5 1/4
2	std 5/8	1/2-20	7/16-20	3/4	1.123	3/8	1/2	1 3/8	9/16	1/4	5/8	1 3/4	3 5/16	1 15/16	4 1/8	4 15/16
	1	7/8-14	3/4-16	1 1/8	1.498	1/2	7/8	2 1/8	15/16	1/2	1	2 1/8	3 11/16	2 5/16	4 1/2	5 5/16
	1 3/8	1 1/4-12	1-14	1 5/8	1.998	5/8	1 1/8	2 7/8	1 5/16	5/8	1 1/4	2 3/8	3 15/16	2 9/16	4 3/8	5 9/16
2.5	5/8	1/2-20	7/16-20	3/4	1.123	3/8	1/2	1 3/8	9/16	1/4	5/8	1 3/4	3 5/16	1 15/16	4 1/4	5 1/16
	std 1	7/8-14	3/4-16	1 1/8	1.498	1/2	7/8	2 1/8	15/16	1/2	1	2 1/8	3 11/16	2 5/16	4 5/8	5 7/16
	1 3/8	1 1/4-12	1-14	1 5/8	1.998	5/8	1 1/8	2 7/8	1 5/16	5/8	1 1/4	2 3/8	3 15/16	2 9/16	4 7/8	5 11/16
	1 3/4	1 1/2-12	1 1/4-12	2	2.373	3/4	1 1/2	3 1/2	1 11/16	3/4	1 1/2	5 5/8	4 3/16	2 13/16	5 1/8	5 15/16
3.25	std 1	7/8-14	3/4-16	1 1/8	1.498	1/2	7/8	1 7/8	15/16	1/4	5/8	2 1/4	4 3/16	1 15/16	5	5 1/16
	1 3/8	1 1/4-12	1-14	1 5/8	1.998	5/8	1 1/8	2 5/8	1 5/16	3/8	1	2 1/2	4 7/16	2 11/16	5 1/4	5 1/4
	1 3/4	1 1/2-12	1 1/4-12	2	2.373	3/4	1 1/2	3 1/4	1 11/16	1/2	1 1/4	2 3/4	4 11/16	2 15/16	5 1/2	6 1/2
	2	1 3/4-12	1 1/2-12	2 1/4	2.623	7/8	1 11/16	3 5/8	1 15/16	1/2	1 3/8	2 7/8	4 13/16	3 1/16	5 5/8	6 5/8
4	1	7/8-14	3/4-16	1 1/8	1.498	1/2	7/8	1 7/8	15/16	1/4	5/8	2 1/4	4 3/16	1 15/16	5	5 1/16
	std 1 3/8	1 1/4-12	1-14	1 5/8	1.998	5/8	1 1/8	2 5/8	1 5/16	3/8	1	2 1/2	4 7/16	2 11/16	5 1/4	5 1/4
	1 3/4	1 1/2-12	1 1/4-12	2	2.373	3/4	1 1/2	3 1/4	1 11/16	1/2	1 1/4	2 3/4	4 11/16	2 15/16	5 1/2	6 1/2
	2	1 3/4-12	1 1/2-12	2 1/4	2.623	7/8	1 11/16	3 5/8	1 15/16	1/2	1 3/8	2 7/8	4 13/16	3 1/16	5 5/8	6 5/8
	2 1/2	2 1/4-12	1 7/8-12	3	3.123	1	2 1/16	4 5/8	2 3/8	5/8	1 5/8	3 1/8	5 1/16	3 5/16	5 7/8	6 7/8
5	1	7/8-14	3/4-16	1 1/8	1.498	1/2	7/8	1 7/8	15/16	1/4	3/4	2 1/4	4 3/16	2 7/16	5 1/4	6 5/16
	1 3/8	1 1/4-12	1-14	1 5/8	1.998	5/8	1 1/8	2 5/8	1 5/16	3/8	1	2 1/2	4 7/16	2 11/16	5 1/2	6 9/16
	std 1 3/4	1 1/2-12	1 1/4-12	2	2.373	3/4	1 1/2	3 1/4	1 11/16	1/2	1 1/4	2 3/4	4 11/16	2 15/16	5 3/4	6 13/16
	2	1 3/4-12	1 1/2-12	2 1/4	2.623	7/8	1 11/16	3 5/8	1 15/16	1/2	1 3/8	2 7/8	4 13/16	3 1/16	5 7/8	6 15/16
	2 1/2	2 1/4-12	1 7/8-12	3	3.123	1	2 1/16	4 5/8	2 3/8	5/8	1 5/8	3 1/8	5 1/16	3 5/16	6 1/8	7 3/16
	3	2 3/4-12	2 1/4-12	3 1/2	3.748	1	2 5/8	5 1/8	2 7/8	5/8	1 5/8	3 1/8	5 1/16	3 5/16	6 1/8	7 3/16
3 1/2	3 1/4-12	2 1/2-12	3 1/2	4.248	1	3	5 1/8	3 3/8	5/8	1 5/8	3 1/8	5 1/16	3 5/16	6 1/8	7 3/16	
6	1 3/8	1 1/4-12	1-14	1 5/8	1.998	5/8	1 1/8	2 1/2	1 5/16	1/4	7/8	2 5/8	4 15/16	2 11/16	5 7/8	7 1/16
	std 1 3/4	1 1/2-12	1 1/4-12	2	2.373	3/4	1 1/2	3 1/8	1 11/16	3/8	1 1/8	2 7/8	5 3/16	3 1/16	6 1/8	7 5/16
	2	1 3/4-12	1 1/2-12	2 1/4	2.623	7/8	1 11/16	3 1/2	1 15/16	3/8	1 1/4	3	5 5/16	3 1/16	6 1/4	7 7/16
	2 1/2	2 1/4-12	1 7/8-12	3	3.123	1	2 1/16	4 1/2	2 3/8	1/2	1 1/2	3 1/4	5 9/16	3 7/16	6 1/2	7 11/16
	3	2 3/4-12	2 1/4-12	3 1/2	3.748	1	2 5/8	5	2 7/8	1/2	1 1/2	3 1/4	5 9/16	3 7/16	6 1/2	7 11/16
	3 1/2	3 1/4-12	2 1/2-12	3 1/2	4.248	1	3	5	3 3/8	1/2	1 1/2	3 1/4	5 9/16	3 7/16	6 1/2	7 11/16
4	3 3/4-12	3-12	4	4.748	1	3 3/8	5 1/2	3 7/8	1/2	1 1/2	3 1/4	5 9/16	3 7/16	6 1/2	7 11/16	

**Dimension XI to be specified by customer.

ST5 SERIES

Medium Duty Hydraulic Cylinders

Clevis Mountings
1 1/2 to 6" Bore Sizes

Cap Fixed Clevis*
Style ST5P1
(NFPA Style MP1)

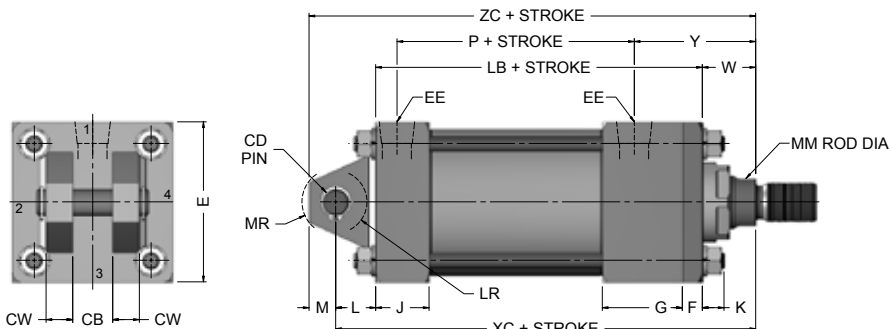

* DETACHABLE IS ALSO AVAILABLE (NFPA MP1)

CAP FIXED EYE MOUNT (NFPA MP3) ALSO AVAILABLE ASK FACTORY

Cap Detachable Clevis
Style ST5P2
(NFPA Style MP2)

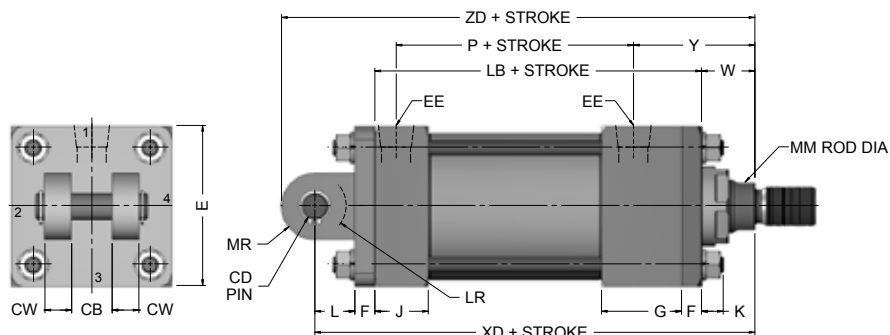

CAP DETACHABLE EYE (NFPA MP4) ALSO AVAILABLE ASK FACTORY

Rod End Dimensions—see table 2

Thread Style #2
(NFPA Style SM)
Small Male

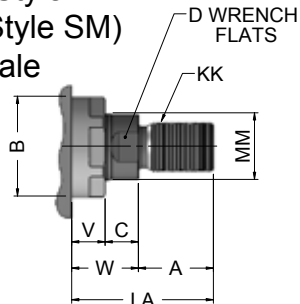

Thread Style #1
(NFPA Style IM)
Intermediate Male

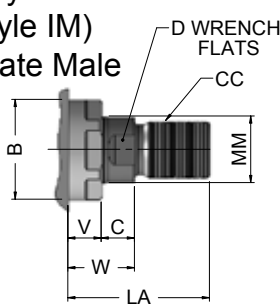

Thread Style #4
(NFPA Style SF)
Small Female

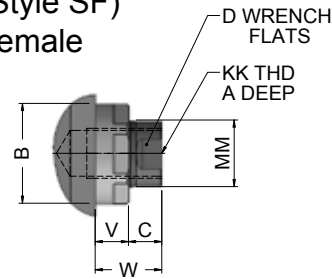

“Specials” Thread Style #X

To order, specify “Style #X” and give desired dimensions for CC or KK, A and LA. If otherwise special, furnish dimensional sketch.

A high strength rod end stud is supplied on thread style #2 through 1" diameter rods and on thread style #1 through 1" diameter rods. Larger sizes or special rod ends are cut threads. Style #2 rod ends are recommended where the workpiece is secured against the rod shoulder. When the workpiece is not shouldered, style 4 rod ends are recommended through 2" piston rod diameters and style #1 rod ends are recommended on larger diameters. Use style #4 for applications where female rod end threads are required. If rod end is not specified, style #2 will be supplied

ST5 SERIES

Medium Duty Hydraulic Cylinders

Clevis Mountings
1 1/2 to 6" Bore Sizes

Table 1—Envelope and Mounting Dimensions

BORE	CB	+.000 CD -.002	CW	E	EE		F	G	J	K	L	LR	M	MR	ADD STROKE	
					NPTF*	SAE**									LB	P
1 1/2	3/4	.501	1/2	2	3/8	6	3/8	1 1/2	1	1/4	3/4	3/4	1/2	5/8	4	2 1/4
2	3/4	.501	1/2	2 1/2	3/8	6	3/8	1 1/2	1	5/16	3/4	3/4	1/2	5/8	4	2 1/4
2 1/2	3/4	.501	1/2	3	3/8	6	3/8	1 1/2	1	5/16	3/4	3/4	1/2	5/8	4 1/8	2 3/8
3 1/4	1 1/4	.751	5/8	3 3/4	1/2	10	5/8	1 3/4	1 1/4	3/8	1 1/4	1	3/4	15/16	4 7/8	2 5/8
4	1 1/4	.751	5/8	4 1/2	1/2	10	5/8	1 3/4	1 1/4	3/8	1 1/4	1	3/4	15/16	4 7/8	2 5/8
5	1 1/4	.751	5/8	5 1/2	1/2	10	5/8	1 3/4	1 1/4	7/16	1 1/4	1	3/4	15/16	5 1/8	2 7/8
6	1 1/2	1.001	3/4	6 1/2	3/4	12	3/4	2	1 1/2	7/16	1 1/2	1 1/4	1	1 3/16	5 3/4	3 1/8

*NPTF ports will be furnished as standard unless SAE straight thread ports are specified.
** SAE straight thread ports are indicated by port number.

Table 2—Rod Dimensions

BORE		ROD SIZE	Thread Style		Rod Extensions and pilot dimensions								Add Stroke				
			STYLE #1	STYLE #2 & #4 KK	A	±.001 B	C	D	LA	NA	V	W	Y	XC	XD	ZC	ZD
1 1/2	std	5/8	1/2-20	7/16-20	3/4	1.123	3/8	1/2	1 3/8	9/16	1/4	5/8	1 15/16	5 3/8	5 3/4	5 7/8	6 1/4
	1	7/8-14	3/4-16	1 1/8	1.498	1/2	7/8	2 1/8	15/16	1/2	1	2 5/16	5 3/4	6 1/8	6 1/4	6 5/8	
2	std	5/8	1/2-20	7/16-20	3/4	1.123	3/8	1/2	1 3/8	9/16	1/4	5/8	1 15/16	5 3/8	5 3/4	5 7/8	6 1/4
	1	7/8-14	3/4-16	1 1/8	1.498	1/2	7/8	2 1/8	15/16	1/2	1	2 5/16	5 3/4	6 1/8	6 1/4	6 5/8	
	1 3/8	1 1/4-12	1-14	1 5/8	1.998	5/8	1 1/8	2 7/8	1 5/16	5/8	1 1/4	2 9/16	6	6 3/8	6 1/2	6 7/8	
2.5		5/8	1/2-20	7/16-20	3/4	1.123	3/8	1/2	1 3/8	9/16	1/4	5/8	1 15/16	5 1/2	5 7/8	6	6 3/8
	std	1	7/8-14	3/4-16	1 1/8	1.498	1/2	7/8	2 1/8	15/16	1/2	1	2 5/16	5 7/8	6 1/4	6 3/8	6 3/4
	1 3/8	1 1/4-12	1-14	1 5/8	1.998	5/8	1 1/8	2 7/8	1 5/16	5/8	1 1/4	2 9/16	6 1/8	6 1/2	6 5/8	7	
	1 3/4	1 1/2-12	1 1/4-12	2	2.373	3/4	1 1/2	3 1/2	1 11/16	3/4	1 1/2	2 13/16	6 3/8	6 3/4	6 7/8	7 1/4	
3.25	std	1	7/8-14	3/4-16	1 1/8	1.498	1/2	7/8	1 7/8	15/16	1/4	5/8	1 15/16	6 7/8	7 1/2	7 5/8	8 1/4
	1 3/8	1 1/4-12	1-14	1 5/8	1.998	5/8	1 1/8	2 5/8	1 5/16	3/8	1	2 11/16	7 1/8	7 3/4	7 7/8	8 1/2	
	1 3/4	1 1/2-12	1 1/4-12	2	2.373	3/4	1 1/2	3 1/4	1 11/16	1/2	1 1/4	2 15/16	7 3/8	8	8 1/8	8 3/4	
	2	1 3/4-12	1 1/2-12	2 1/4	2.623	7/8	1 11/16	3 5/8	1 15/16	1/2	1 3/8	3 1/16	7 1/2	8 1/8	8 1/4	8 7/8	
4		1	7/8-14	3/4-16	1 1/8	1.498	1/2	7/8	1 7/8	15/16	1/4	5/8	1 15/16	6 7/8	7 1/2	7 5/8	8 1/4
	std	1 3/8	1 1/4-12	1-14	1 5/8	1.998	5/8	1 1/8	2 5/8	1 5/16	3/8	1	2 11/16	7 1/8	7 3/4	7 7/8	8 1/2
	1 3/4	1 1/2-12	1 1/4-12	2	2.373	3/4	1 1/2	3 1/4	1 11/16	1/2	1 1/4	2 15/16	7 3/8	8	8 1/8	8 3/4	
	2	1 3/4-12	1 1/2-12	2 1/4	2.623	7/8	1 11/16	3 5/8	1 15/16	1/2	1 3/8	3 1/16	7 1/2	8 1/8	8 1/4	8 7/8	
	2 1/2	2 1/4-12	1 7/8-12	3	3.123	1	2 1/16	4 5/8	2 3/8	5/8	1 5/8	3 5/16	7 3/4	8 3/8	8 1/2	9 1/8	
5		1	7/8-14	3/4-16	1 1/8	1.498	1/2	7/8	1 7/8	15/16	1/4	3/4	2 7/16	7 1/8	7 3/4	7 7/8	8 1/2
	1 3/8	1 1/4-12	1-14	1 5/8	1.998	5/8	1 1/8	2 5/8	1 5/16	3/8	1	2 11/16	7 3/8	8	8 1/8	8 3/4	
	std	1 3/4	1 1/2-12	1 1/4-12	2	2.373	3/4	1 1/2	3 1/4	1 11/16	1/2	1 1/4	2 15/16	7 5/8	8 1/4	8 3/8	9
	2	1 3/4-12	1 1/2-12	2 1/4	2.623	7/8	1 11/16	3 5/8	1 15/16	1/2	1 3/8	3 1/16	7 3/4	8 3/8	8 1/2	9 1/8	
	2 1/2	2 1/4-12	1 7/8-12	3	3.123	1	2 1/16	4 5/8	2 3/8	5/8	1 5/8	3 5/16	8	8 5/8	8 3/4	9 3/8	
	3	2 3/4-12	2 1/4-12	3 1/2	3.748	1	2 5/8	5 1/8	2 7/8	5/8	1 5/8	3 5/16	8	8 5/8	8 3/4	9 3/8	
	3 1/2	3 1/4-12	2 1/2-12	3 1/2	4.248	1	3	5 1/8	3 3/8	5/8	1 5/8	3 5/16	8	8 5/8	8 3/4	9 3/8	
6		1 3/8	1 1/4-12	1-14	1 5/8	1.998	5/8	1 1/8	2 1/2	1 5/16	1/4	7/8	2 11/16	8 1/8	8 7/8	9 1/8	9 7/8
	std	1 3/4	1 1/2-12	1 1/4-12	2	2.373	3/4	1 1/2	3 1/8	1 11/16	3/8	1 1/8	3 1/16	8 3/8	9 1/8	9 3/8	10 1/8
	2	1 3/4-12	1 1/2-12	2 1/4	2.623	7/8	1 11/16	3 1/2	1 15/16	3/8	1 1/4	3 1/16	8 1/2	9 1/4	9 1/2	10 1/4	
	2 1/2	2 1/4-12	1 7/8-12	3	3.123	1	2 1/16	4 1/2	2 3/8	1/2	1 1/2	3 7/16	8 3/4	9 1/2	9 3/4	10 1/2	
	3	2 3/4-12	2 1/4-12	3 1/2	3.748	1	2 5/8	5	2 7/8	1/2	1 1/2	3 7/16	8 3/4	9 1/2	9 3/4	10 1/2	
	3 1/2	3 1/4-12	2 1/2-12	3 1/2	4.248	1	3	5	3 3/8	1/2	1 1/2	3 7/16	8 3/4	9 1/2	9 3/4	10 1/2	
	4	3 3/4-12	3-12	4	4.748	1	3 3/8	5 1/2	3 7/8	1/2	1 1/2	3 7/16	8 3/4	9 1/2	9 3/4	10 1/2	

Table 3—Envelope and Mounting Dimensions

Double Rod End and
Head Rectangular Mount
1 1/2 to 6" Bore Sizes

ST5 SERIES

Medium Duty Hydraulic Cylinders

Head Rectangular
Style ST5E5
(*NOT NFPA - JJ Style ME5)

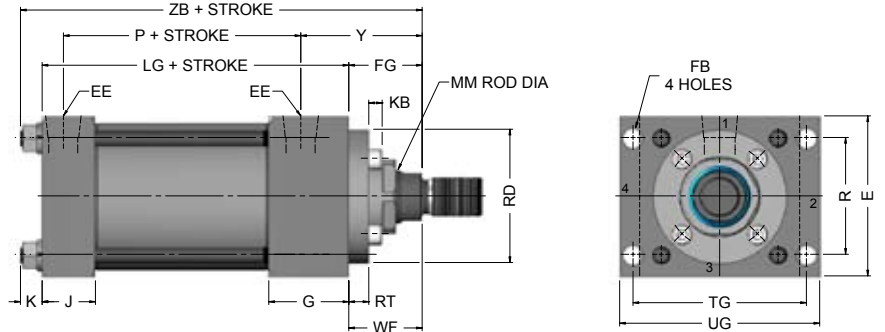

Double Rod end
Style ST5D

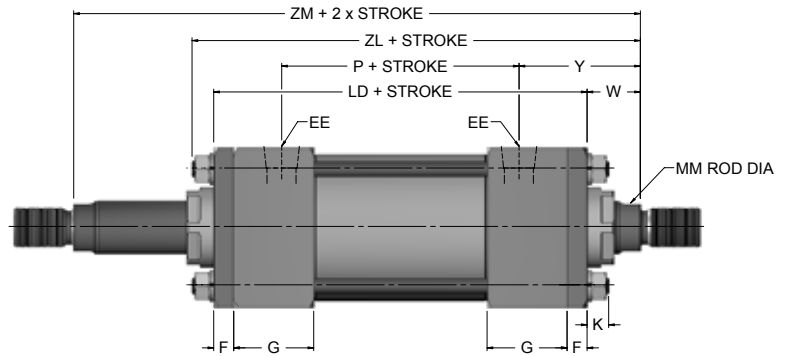

Rod End Dimensions—see table 2

Thread Style #2
(NFPA Style SM)
Small Male

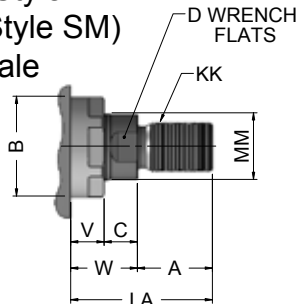

Thread Style #1
(NFPA Style IM)
Intermediate Male

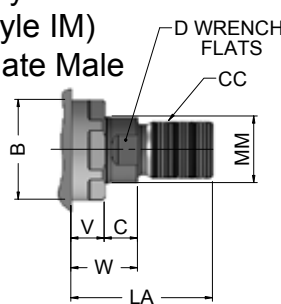

Thread Style #4
(NFPA Style SF)
Small Female

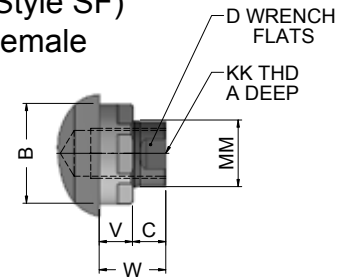

“Specials” Thread Style #X

To order, specify “Style #X” and give desired dimensions for CC or KK, A and LA. If otherwise special, furnish dimensional sketch.

A high strength rod end stud is supplied on thread style #2 through 1" diameter rods and on thread style #1 through 1" diameter rods. Larger sizes or special rod ends are cut threads. Style #2 rod ends are recommended where the workpiece is secured against the rod shoulder. When the workpiece is not shouldered, style 4 rod ends are recommended through 2" piston rod diameters and style #1 rod ends are recommended on larger diameters. Use style #4 for applications where female rod end threads are required. If rod end is not specified, style #2 will be supplied

ST5 SERIES

Medium Duty Hydraulic Cylinders

Double Rod End and
Head Rectangular Mount
1 1/2 to 6" Bore Sizes

Table 1—Envelope and Mounting Dimensions

BORE	E	EE		FB	G	J	K	R	UG	TG	ADD STROKE	
		NPTF*	SAE**								LG	P
1 1/2	2	3/8	6	3/8	1 1/2	1	1/4	1.43	2 3/4	2 5/16	3 5/8	2 1/4
2	2 1/2	3/8	6	3/8	1 1/2	1	5/16	1.84	3 3/8	2 7/8	3 5/8	2 1/4
2 1/2	3	3/8	6	3/8	1 1/2	1	5/16	2.19	3 3/4	3 1/4	3 3/4	2 3/8
3 1/4	3 3/4	1/2	10	5/8	1 3/4	1 1/4	3/8	2.76	4 5/8	4	4 1/4	2 5/8
4	4 1/2	1/2	10	5/8	1 3/4	1 1/4	3/8	3.32	5 1/8	4 1/2	4 1/4	2 5/8
5	5 1/2	1/2	10	5/8	1 3/4	1 1/4	7/16	4.10	6 7/16	5 5/8	4 1/2	2 7/8
6	6 1/2	3/4	12	3/4	2	1 1/2	7/16	4.88	7 1/4	6 7/16	5	3 1/8

*NPTF ports will be furnished as standard unless SAE straight thread ports are specified.
** SAE straight thread ports are indicated by port number.

Table 2—Rod Dimensions

BORE	ROD SIZE	Thread Style		Rod Extensions and pilot dimensions									Add Stroke	
		STYLE #1	STYLE #2 & #4 KK	A	±.001 B	C	D	RT	MAX. RD	KB	WF	Y	XC	
1 1/2	std	5/8	1/2-20	7/16-20	3/4	1.123	3/8	1/2	1/4	1.967	3/16	1	1 15/16	4 7/8
2	std	5/8	1/2-20	7/16-20	3/4	1.123	3/8	1/2	1/4	1.967	3/16	1	1 15/16	4 15/16
		1	7/8-14	3/4-16	1 1/8	1.498	1/2	7/8	3/8	2.467	1/4	1 3/8	2 5/16	5 5/16
2 1/2	std	1	7/8-14	3/4-16	1 1/8	1.498	1/2	7/8	3/8	2.467	1/4	1 3/8	2 5/16	5 7/16
		1 3/8	1 1/4-12	1-14	1 5/8	1.998	5/8	1 1/8	3/8	2.967	1/4	1 5/8	2 9/16	5 11/16
3 1/4	std	1	7/8-14	3/4-16	1 1/8	1.498	1/2	7/8	3/8	2.467	1/4	1 3/8	1 15/16	6
		1 3/8	1 1/4-12	1-14	1 5/8	1.998	5/8	1 1/8	3/8	2.967	1/4	1 5/8	2 11/16	6 1/4
4	std	1 3/8	1 1/4-12	1-14	1 5/8	1.998	5/8	1 1/8	3/8	2.967	1/4	1 5/8	2 11/16	6 1/4
		1 3/4	1 1/2-12	1 1/4-12	2	2.373	3/4	1 1/2	3/8	3.467	1/4	1 7/8	2 15/16	6 1/2
5	std	1 3/4	1 1/2-12	1 1/4-12	2	2.373	3/4	1 1/2	3/8	3.467	1/4	1 7/8	2 15/16	6 13/16
		2	1 3/4-12	1 1/2-12	2 1/4	2.623	7/8	1 11/16	3/8	3.717	1/4	2	3 1/16	6 15/16
6	std	1 3/4	1 1/2-12	1 1/4-12	2	2.373	3/4	1 1/2	3/8	3.467	1/4	1 7/8	3 1/16	7 5/16
		2	1 3/4-12	1 1/2-12	2 1/4	2.623	7/8	1 11/16	3/8	3.717	1/4	2	3 1/16	7 7/16

Table 3—Envelope and Mounting Dimensions

DOUBLE ROD END

To determine dimensions for a double rod cylinder, first refer to the desired single rod mounting style cylinder shown on preceding pages of this catalog. After selecting necessary dimensions from that drawing, return to this page supplement the single rod dimensions with those shown on drawings above and dimension table below. Note that double rod cylinders have a head (Dim. G) at both ends and that dimension LD replaces LB and ZL replaces ZB, etc. The double rod dimensions differ from, or are in addition to those for single rod cylinders shown on preceding pages and provide the information needed to completely dimension a double rod cylinder. On a double rod cylinder where the two rod ends are different, be sure to clearly state which rod end is to be assembled at which end. Port position 1 is standard. If other than standard, specify pos. 2, 3 or 4 when viewed from rod end #1 only. (See port position information in Page 24.)

BORE	ROD SIZE	Add Stroke							Add 2X Stroke	
		LD	ZL	SS _D	SN _D	SE _D	XE _D	ZE _D	ZM	
1 1/2	std	5/8	4 7/8	5 3/4	3 3/8	2 1/4	6 3/8	6 1/4	6 1/2	6 1/8
2	std	5/8	4 7/8	5 13/16	3 3/8	2 1/4	6 3/4	6 7/16	6 3/4	6 1/8
2 1/2	std	1	5	6 5/16	3 1/2	2 3/8	7 1/8	7 1/16	7 3/8	7
3 1/4	std	1	6	7 1/8	3 3/4	2 5/8	7 3/4	7 5/8	8	7 1/2
4	std	1 3/8	6	7 3/8	3 3/4	2 5/8	8	8	8 3/8	8
5	std	1 3/4	6 1/4	7 15/16	3 5/8	2 7/8	8 3/8	8 9/16	9 1/16	8 3/4
6	std	1 3/4	7	8 11/16	4 1/8	3 1/8	9	9 1/8	9 5/8	9 1/4
Replaces :		LB	ZB	SS	SN	SE	XE	ZE	--	
On single rod mounting styles:		All Mtgs. Style		MS2, MS3	MS4	MS7			All Mtgs.	

All dimensions are in inches and apply to standard rod sizes only. For alternate rod sizes, determine all envelope dimensions (within LD dim.) as described above and then use appropriate rod end dimensions for proper rod size from single rod cylinder.

**Tie Rod, Head Square and
Cap Square Mountings
8" Bore Size**

ST5 SERIES

Medium Duty Hydraulic Cylinders

**Tie Rods Extended
Style ST5X3
(NFPA Style MX3)**

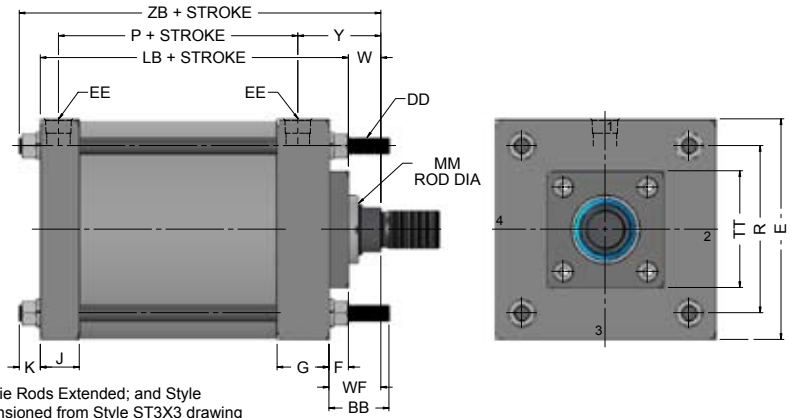

Style ST5X3 (NFPA MX3) Head Tie Rods Extended, illustrated: Style ST5X2 (NFPA MX2), Cap Tie Rods Extended; and Style ST3X1 (NFPA MX1), Both Ends Tie Rods Extended are also available. All "T" styles can be dimensioned from Style ST3X3 drawing at right. Basic Mounting ST3X0 — NFPA MX0 — no tie rods extended can be supplied upon request.

**Head Square Flange
Style ST5E3
(NFPA Style ME3)**

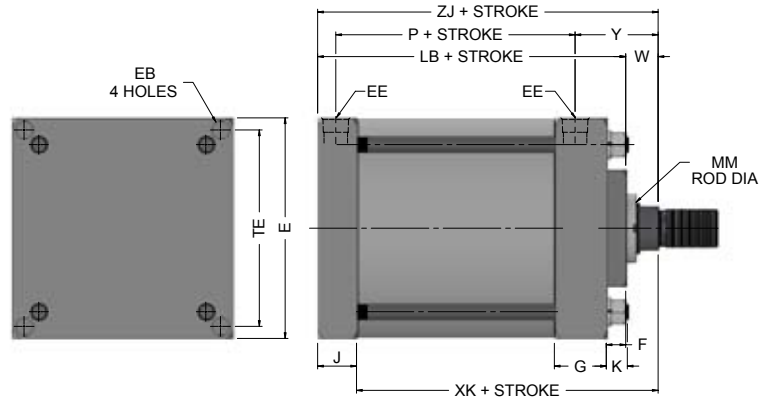

**Cap Square Flange
Style ST5E4
(NFPA Style ME4)**

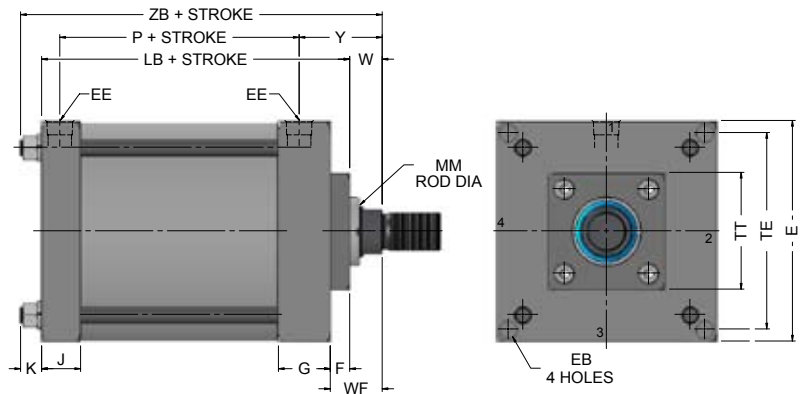

Rod End Dimensions—see table 2

**Thread Style #2
(NFPA Style SM)
Small Male**

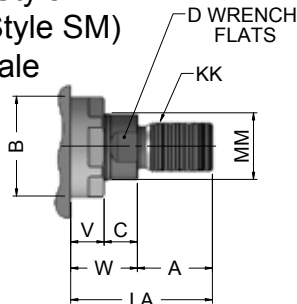

**Thread Style #1
(NFPA Style IM)
Intermediate Male**

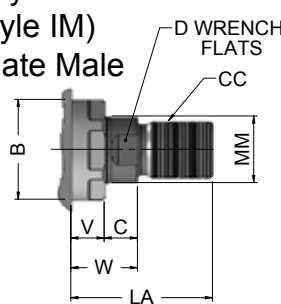

**Thread Style #4
(NFPA Style SF)
Small Female**

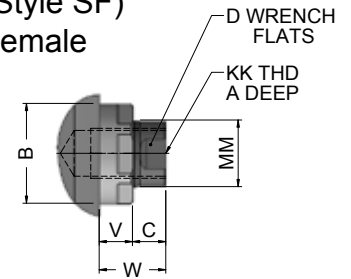

"Specials" Thread #X

To order, specify "Style #X" and give desired dimensions for CC or KK, A and LA. If otherwise special, furnish dimensional sketch.

A high strength rod end stud is supplied on thread style #2 through 1" diameter rods and on thread style #1 through 1" diameter rods. Larger sizes or special rod ends are cut threads. Style #2 rod ends are recommended where the workpiece is secured against the rod shoulder. When the workpiece is not shouldered, style 4 rod ends are recommended through 2" piston rod diameters and style #1 rod ends are recommended on larger diameters. Use style #4 for applications where female rod end threads are required. If rod end is not specified, style #2 will be supplied

ST5 SERIES

Medium Duty Hydraulic Cylinders

Tie Rod, Head Square and
Cap Square Mountings
8" Bore Size

Table 1—Envelope and Mounting Dimensions- MX1, MX2, MX3 style

BORE	AA	BB	DD	E	EE		F	G	J	K	R	ADD STROKE	
					NPTF*	SAE**						LB	P
8	9.1	2 5/16	5/8-18	8 1/2	3/4	12	3/4	2	1 1/2	9/16	6.44	5 7/8	3 1/4

*NPTF ports will be furnished as standard unless SAE straight thread ports are specified.
** SAE straight thread ports are indicated by port number.

Table 2—Rod Dimensions - MX1, MX2, MX3 style

BORE	ROD SIZE	Thread Style		Rod Extensions and pilot dimensions								TT	WF	Y	Add Stroke ZB
		STYLE #1	STYLE #2 & #4 KK	A	±.001 B	C	D	LA	NA	V	W				
8	1 3/8	1 1/4-12	1-14	1 5/8	1.998	5/8	1 1/8	2 1/2	1 5/16	1/4	7/8	4	1 5/8	2 13/16	7 5/16
	1 3/4	1 1/2-12	1 1/4-12	2	2.373	3/4	1 1/2	3 1/8	1 11/16	3/8	1 1/8	4	1 7/8	3 1/16	7 9/16
	std 2	1 3/4-12	1 1/2-12	2 1/4	2.623	7/8	1 11/16	3 1/2	1 5/16	3/8	1 1/4	4	2	3 3/16	7 11/16
	2 1/2	2 1/4-12	1 7/8-12	3	3.123	1	2 1/16	4 1/2	2 3/8	1/2	1 1/2	4	2 1/4	3 7/16	7 15/16
	3	2 3/4-12	2 1/4-12	3 1/2	3.748	1	2 5/8	5	2 7/8	1/2	1 1/2	5 1/2	2 1/4	3 7/16	7 15/16
	3 1/2	3 1/4-12	2 1/2-12	3 1/2	4.248	1	3	5	3 3/8	1/2	1 1/2	5 1/2	2 1/4	3 7/16	7 15/16
	4	3 3/4-12	3-12	4	4.748	1	3 3/8	5 1/2	3 7/8	1/2	1 1/2	5 1/2	2 1/4	3 7/16	7 15/16
	4 1/2	4 1/4-12	3 1/4-12	4 1/2	5.248	1	3 7/8	6	4 3/8	1/2	1 1/2	7	2 1/4	3 7/16	7 15/16
	5	4 3/4-12	3 1/2-12	5	5.748	1	4 1/4	6 1/2	4 7/8	1/2	1 1/2	7	2 1/4	3 7/16	7 15/16
5 1/2	5 1/4-12	4-12	5 1/2	6.248	1	4 5/8	7	5 3/8	1/2	1 1/2	7	2 1/4	3 7/16	7 15/16	

Table 3—Envelope and Mounting Dimensions

Table 1—Envelope and Mounting Dimensions - ME3, ME4 styles

BORE	E	EE		F	G	J	K	TE	ADD STROKE	
		NPTF*	SAE**						LB	P
8	8 1/2	3/4	12	3/4	2	1 1/2	9/16	7.57	5 7/8	3 1/4

*NPTF ports will be furnished as standard unless SAE straight thread ports are specified.
** SAE straight thread ports are indicated by port number.

Table 2—Rod Dimensions - ME3, ME4, style

BORE	ROD SIZE	Thread Style		Rod Extensions and pilot dimensions								TT	WF	Y	Add Stroke		
		STYLE #1	STYLE #2 & #4 KK	A	±.001 B	C	D	LA	NA	V	W				XK	ZB	ZJ
8	1 3/8	1 1/4-12	1-14	1 5/8	1.998	5/8	1 1/8	2 1/2	1 5/16	1/4	7/8	4	1 5/8	2 13/16	5 1/4	7 5/16	6 3/4
	1 3/4	1 1/2-12	1 1/4-12	2	2.373	3/4	1 1/2	3 1/8	1 11/16	3/8	1 1/8	4	1 7/8	3 1/16	5 1/2	7 9/16	7
	std 2	1 3/4-12	1 1/2-12	2 1/4	2.623	7/8	1 11/16	3 1/2	1 5/16	3/8	1 1/4	4	2	3 3/16	5 5/8	7 11/16	7 1/8
	2 1/2	2 1/4-12	1 7/8-12	3	3.123	1	2 1/16	4 1/2	2 3/8	1/2	1 1/2	4	2 1/4	3 7/16	5 7/8	7 15/16	7 3/8
	3	2 3/4-12	2 1/4-12	3 1/2	3.748	1	2 5/8	5	2 7/8	1/2	1 1/2	5 1/2	2 1/4	3 7/16	5 7/8	7 15/16	7 3/8
	3 1/2	3 1/4-12	2 1/2-12	3 1/2	4.248	1	3	5	3 3/8	1/2	1 1/2	5 1/2	2 1/4	3 7/16	5 7/8	7 15/16	7 3/8
	4	3 3/4-12	3-12	4	4.748	1	3 3/8	5 1/2	3 7/8	1/2	1 1/2	5 1/2	2 1/4	3 7/16	5 7/8	7 15/16	7 3/8
	4 1/2	4 1/4-12	3 1/4-12	4 1/2	5.248	1	3 7/8	6	4 3/8	1/2	1 1/2	7	2 1/4	3 7/16	5 7/8	7 15/16	7 3/8
	5	4 3/4-12	3 1/2-12	5	5.748	1	4 1/4	6 1/2	4 7/8	1/2	1 1/2	7	2 1/4	3 7/16	5 7/8	7 15/16	7 3/8
5 1/2	5 1/4-12	4-12	5 1/2	6.248	1	4 5/8	7	5 3/8	1/2	1 1/2	7	2 1/4	3 7/16	5 7/8	7 15/16	7 3/8	

Table 3—Envelope and Mounting Dimensions

Side and Centerline Lugs and Side Tapped Mountings
8" Bore Size

ST5 SERIES

Medium Duty Hydraulic Cylinders

Side Lugs
Style ST5S2
(NFFPA Style MS2)

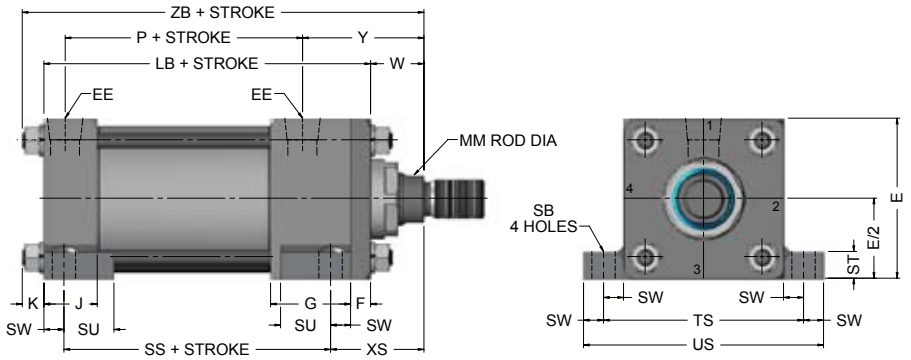

Centerline Lugs
Style ST5S3
(NFFPA Style MS3)

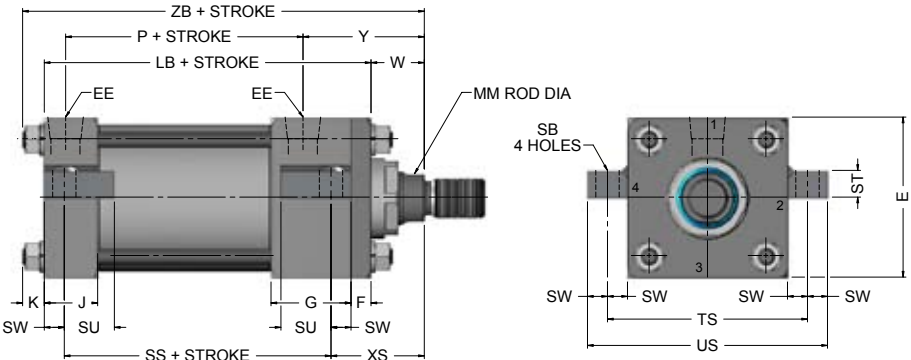

Side Tapped
Style ST5S4
(NFFPA Style MS4)

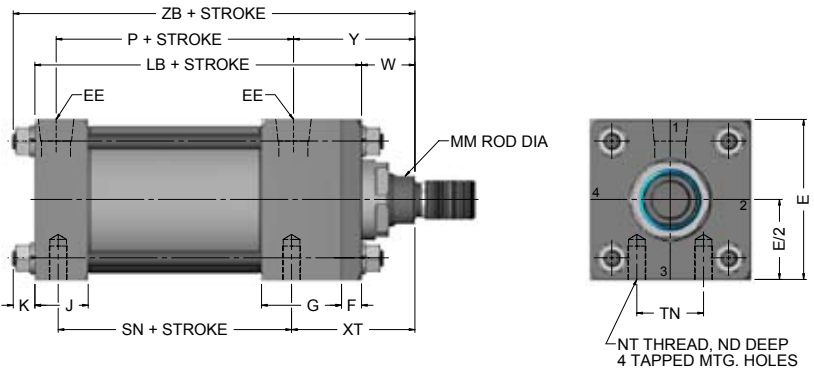

Rod End Dimensions—see table 2

Thread Style #2
(NFFPA Style SM)
Small Male

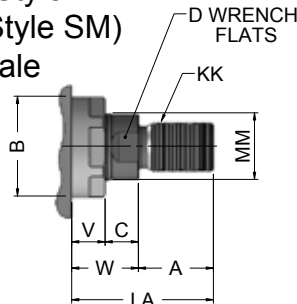

Thread Style #1
(NFFPA Style IM)
Intermediate Male

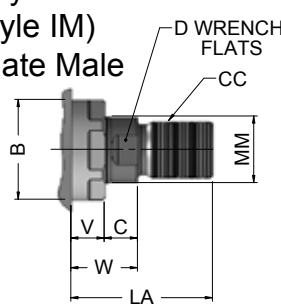

Thread Style #4
(NFFPA Style SF)
Small Female

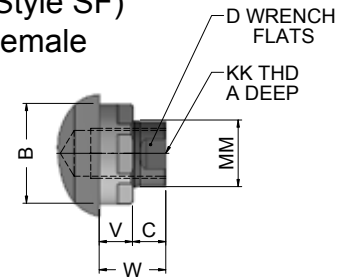

“Specials” Thread Style #X

To order, specify “Style #X” and give desired dimensions for CC or KK, A and LA. If otherwise special, furnish dimensional sketch.

A high strength rod end stud is supplied on thread style #2 through 1" diameter rods and on thread style #1 through 1" diameter rods. Larger sizes or special rod ends are cut threads. Style #2 rod ends are recommended where the workpiece is secured against the rod shoulder. When the workpiece is not shouldered, style 4 rod ends are recommended through 2" piston rod diameters and style #1 rod ends are recommended on larger diameters. Use style #4 for applications where female rod end threads are required. If rod end is not specified, style #2 will be supplied

ST5 SERIES

Medium Duty Hydraulic Cylinders

Side and Centerline Lugs and
Side Tapped Mountings
8" Bore Size

Table 1—Envelope and Mounting Dimensions- MS2, MS3 style

BORE	E	EE		F	G	J	K	SB*	ST	SU	SW	TS	US	ADD STROKE		
		NPTF*	SAE**											LB	P	SS
8	8 1/2	3/4	12	3/4	2	1 1/2	9/16	13/16	1	1 9/16	11/16	9 7/8	11 1/4	5 7/8	3 1/4	3 3/4

*NPTF ports will be furnished as standard unless SAE straight thread ports are specified.

** SAE straight thread ports are indicated by port number.

* Upper surface spot faced for socket head screws.

Table 2—Rod Dimensions - MS2, MS3 style

BORE	ROD SIZE	Thread Style		Rod Extensions and pilot dimensions								TT	XS	Y	Add Stroke ZB
		STYLE #1	STYLE #2 & #4 KK	A	±.001 B	C	D	LA	NA	V	W				
8	1 3/8	1 1/4-12	1-14	1 5/8	1.998	5/8	1 1/8	2 1/2	1 5/16	1/4	7/8	4	2 5/16	2 13/16	7 5/16
	1 3/4	1 1/2-12	1 1/4-12	2	2.373	3/4	1 1/2	3 1/8	1 11/16	3/8	1 1/8	4	2 9/16	3 1/16	7 9/16
	std 2	1 3/4-12	1 1/2-12	2 1/4	2.623	7/8	1 11/16	3 1/2	1 5/16	3/8	1 1/4	4	2 11/16	3 3/16	7 11/16
	2 1/2	2 1/4-12	1 7/8-12	3	3.123	1	2 1/16	4 1/2	2 3/8	1/2	1 1/2	4	2 15/16	3 7/16	7 15/16
	3	2 3/4-12	2 1/4-12	3 1/2	3.748	1	2 5/8	5	2 7/8	1/2	1 1/2	5 1/2	2 15/16	3 7/16	7 15/16
	3 1/2	3 1/4-12	2 1/2-12	3 1/2	4.248	1	3	5	3 3/8	1/2	1 1/2	5 1/2	2 15/16	3 7/16	7 15/16
	4	3 3/4-12	3-12	4	4.748	1	3 3/8	5 1/2	3 7/8	1/2	1 1/2	5 1/2	2 15/16	3 7/16	7 15/16
	4 1/2	4 1/4-12	3 1/4-12	4 1/2	5.248	1	3 7/8	6	4 3/8	1/2	1 1/2	7	2 15/16	3 7/16	7 15/16
	5	4 3/4-12	3 1/2-12	5	5.748	1	4 1/4	6 1/2	4 7/8	1/2	1 1/2	7	2 15/16	3 7/16	7 15/16
	5 1/2	5 1/4-12	4-12	5 1/2	6.248	1	4 5/8	7	5 3/8	1/2	1 1/2	7	2 15/16	3 7/16	7 15/16

Table 3—Envelope and Mounting Dimensions

Table 1—Envelope and Mounting Dimensions - MS4 style

BORE	E	EE		F	G	J	K	SB*	ND	NT	TN	ADD STROKE		
		NPTF*	SAE**									LB	P	SN
8	8 1/2	3/4	12	3/4	2	1 1/2	9/16	13/16	11/8	3/4-10	4 1/2	5 7/8	3 1/4	3 1/4

*NPTF ports will be furnished as standard unless SAE straight thread ports are specified.

** SAE straight thread ports are indicated by port number.

Table 2—Rod Dimensions - MS4, style

BORE	ROD SIZE	Thread Style		Rod Extensions and pilot dimensions								TT	XT	Y	Add Stroke ZB
		STYLE #1	STYLE #2 & #4 KK	A	±.001 B	C	D	LA	NA	V	W				
8	1 3/8	1 1/4-12	1-14	1 5/8	1.998	5/8	1 1/8	2 1/2	1 5/16	1/4	7/8	4	2 13/16	2 13/16	7 5/16
	1 3/4	1 1/2-12	1 1/4-12	2	2.373	3/4	1 1/2	3 1/8	1 11/16	3/8	1 1/8	4	3 1/16	3 1/16	7 9/16
	std 2	1 3/4-12	1 1/2-12	2 1/4	2.623	7/8	1 11/16	3 1/2	1 5/16	3/8	1 1/4	4	3 3/16	3 3/16	7 11/16
	2 1/2	2 1/4-12	1 7/8-12	3	3.123	1	2 1/16	4 1/2	2 3/8	1/2	1 1/2	4	3 7/16	3 7/16	7 15/16
	3	2 3/4-12	2 1/4-12	3 1/2	3.748	1	2 5/8	5	2 7/8	1/2	1 1/2	5 1/2	3 7/16	3 7/16	7 15/16
	3 1/2	3 1/4-12	2 1/2-12	3 1/2	4.248	1	3	5	3 3/8	1/2	1 1/2	5 1/2	3 7/16	3 7/16	7 15/16
	4	3 3/4-12	3-12	4	4.748	1	3 3/8	5 1/2	3 7/8	1/2	1 1/2	5 1/2	3 7/16	3 7/16	7 15/16
	4 1/2	4 1/4-12	3 1/4-12	4 1/2	5.248	1	3 7/8	6	4 3/8	1/2	1 1/2	7	3 7/16	3 7/16	7 15/16
	5	4 3/4-12	3 1/2-12	5	5.748	1	4 1/4	6 1/2	4 7/8	1/2	1 1/2	7	3 7/16	3 7/16	7 15/16
	5 1/2	5 1/4-12	4-12	5 1/2	6.248	1	4 5/8	7	5 3/8	1/2	1 1/2	7	3 7/16	3 7/16	7 15/16

Table 3—Envelope and Mounting Dimensions

Side End Lugs and Clevis Mountings
8" Bore Size

ST5 SERIES

Medium Duty Hydraulic Cylinders

Side End Lugs
Style ST5S7
(NFFPA Style MS7)

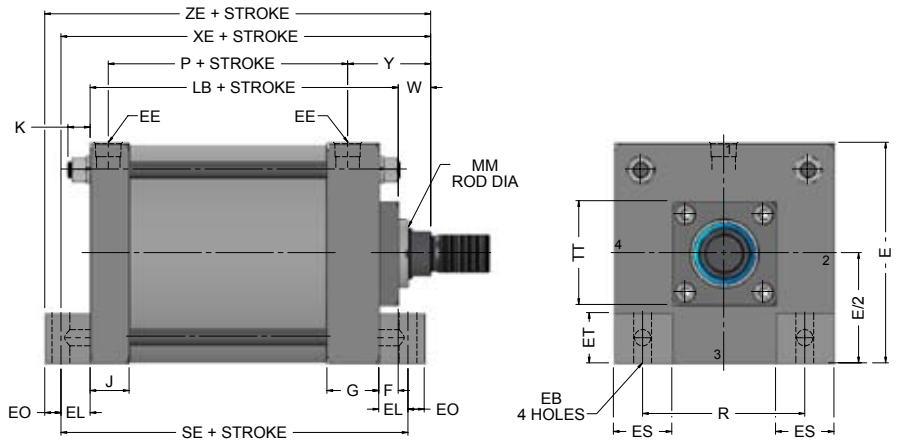

Cap Fixed Clevis
Style ST5P1
(NFFPA Style MP1)

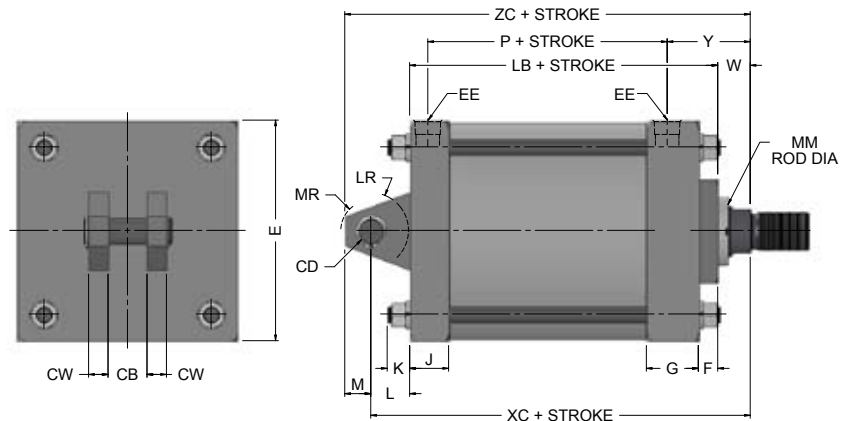

Cylinders with this mounting style are mounted on the precision ground surfaces of the head and cap. There must be a minimum gap of at least 1/64 of an inch between the bottom of the lug and the mounting surface before the mounting bolts are tightened.

Rod End Dimensions—see table 2

Thread Style #2
(NFFPA Style SM)
Small Male

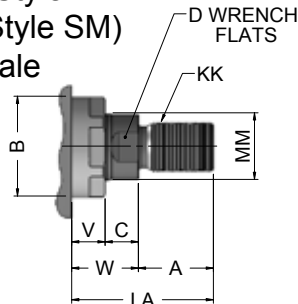

Thread Style #1
(NFFPA Style IM)
Intermediate Male

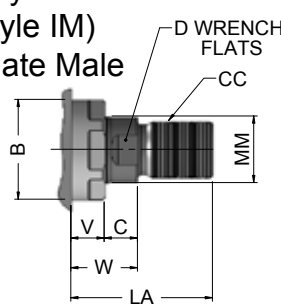

Thread Style #4
(NFFPA Style SF)
Small Female

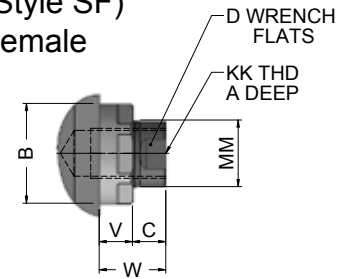

“Specials” Thread Style #X

To order, specify “Style #X” and give desired dimensions for CC or KK, A and LA. If otherwise special, furnish dimensional sketch.

A high strength rod end stud is supplied on thread style #2 through 1" diameter rods and on thread style #1 through 1" diameter rods. Larger sizes or special rod ends are cut threads. Style #2 rod ends are recommended where the workpiece is secured against the rod shoulder. When the workpiece is not shouldered, style 4 rod ends are recommended through 2" piston rod diameters and style #1 rod ends are recommended on larger diameters. Use style #4 for applications where female rod end threads are required. If rod end is not specified, style #2 will be supplied

ST5 SERIES

Medium Duty Hydraulic Cylinders

Side End Lugs and
Clevis Mountings
8" Bore Size

Table 1—Envelope and Mounting Dimensions- MS2 style

BORE	E	EB	EE		EL	EO	ES	ET	F	G	J	K	NT	R	ADD STROKE		
			NPTF*	SAE**											LB	P	SE
8	8 1/2	11/16	3/4	12	1 1/8	5/8	2 1/4	1 15/16	3/4	2	1 1/2	9/16	13/16	1	5 7/8	3 1/4	7 3/8

*NPTF ports will be furnished as standard unless SAE straight thread ports are specified.

** SAE straight thread ports are indicated by port number.

Table 2—Rod Dimensions - MS7 style

BORE	ROD SIZE	Thread Style		Rod Extensions and pilot dimensions								Add Stroke			
		STYLE #1	STYLE #2 & #4 KK	A	±.001 B	C	D	LA	NA	V	W	TT	Y	XE	ZE
8	1 3/8	1 1/4-12	1-14	1 5/8	1.998	5/8	1 1/8	2 1/2	1 5/16	1/4	7/8	4	2 13/16	7 7/8	8 1/2
	1 3/4	1 1/2-12	1 1/4-12	2	2.373	3/4	1 1/2	3 1/8	1 11/16	3/8	1 1/8	4	3 1/16	8 1/8	8 3/4
	std 2	1 3/4-12	1 1/2-12	2 1/4	2.623	7/8	1 11/16	3 1/2	1 5/16	3/8	1 1/4	4	3 3/16	8 1/4	8 7/8
	2 1/2	2 1/4-12	1 7/8-12	3	3.123	1	2 1/16	4 1/2	2 3/8	1/2	1 1/2	4	3 7/16	8 1/2	9 1/8

*Mounting style MS7 not offered in all rod size.

Caution: When using mounting style G, check clearance between mounting members and rod attachment or accessory.

If necessary, specify longer rod extension to avoid interference with mounting members.

Table 3—Envelope and Mounting Dimensions

Table 1—Envelope and Mounting Dimensions - MP1 style

BORE	CB	+.000 -.002 CD*	CW	E	EE		F	G	J	K	L	LR	M	ADD STROKE		
					NPTF*	SAE**								MR	LB	P
8	1 1/2	1.001	3/4	8 1/2	3/4	12	3/4	2	1 1/2	9/16	1 1/2	1 1/4	1	1 3/16	5 7/8	3 1/4

*NPTF ports will be furnished as standard unless SAE straight thread ports are specified.

** SAE straight thread ports are indicated by port number.

* Dimension CD is pin diameter

Table 2—Rod Dimensions - MP1, style

BORE	ROD SIZE	Thread Style		Rod Extensions and pilot dimensions								Add Stroke		
		STYLE #1	STYLE #2 & #4 KK	A	±.001 B	C	D	LA	NA	V	W	Y	XC	ZC
8	1 3/8	1 1/4-12	1-14	1 5/8	1.998	5/8	1 1/8	2 1/2	1 5/16	1/4	7/8	2 13/16	8 1/4	9 1/4
	1 3/4	1 1/2-12	1 1/4-12	2	2.373	3/4	1 1/2	3 1/8	1 11/16	3/8	1 1/8	3 1/16	8 1/2	9 1/2
	std 2	1 3/4-12	1 1/2-12	2 1/4	2.623	7/8	1 11/16	3 1/2	1 5/16	3/8	1 1/4	3 3/16	8 5/8	9 5/8
	2 1/2	2 1/4-12	1 7/8-12	3	3.123	1	2 1/16	4 1/2	2 3/8	1/2	1 1/2	3 7/16	8 7/8	9 7/8
	3	2 3/4-12	2 1/4-12	3 1/2	3.748	1	2 5/8	5	2 7/8	1/2	1 1/2	3 7/16	8 7/8	9 7/8
	3 1/2	3 1/4-12	2 1/2-12	3 1/2	4.248	1	3	5	3 3/8	1/2	1 1/2	3 7/16	8 7/8	9 7/8
	4	3 3/4-12	3-12	4	4.748	1	3 3/8	5 1/2	3 7/8	1/2	1 1/2	3 7/16	8 7/8	9 7/8
	4 1/2	4 1/4-12	3 1/4-12	4 1/2	5.248	1	3 7/8	6	4 3/8	1/2	1 1/2	3 7/16	8 7/8	9 7/8
	5	4 3/4-12	3 1/2-12	5	5.748	1	4 1/4	6 1/2	4 7/8	1/2	1 1/2	3 7/16	8 7/8	9 7/8
	5 1/2	5 1/4-12	4-12	5 1/2	6.248	1	4 5/8	7	5 3/8	1/2	1 1/2	3 7/16	8 7/8	9 7/8

Table 3—Envelope and Mounting Dimensions

ST5 SERIES

Medium Duty Hydraulic Cylinders

Trunnion Mountings
8" Bore Size

Head Trunnion
Style ST5T1
(NFPA Style MT1)

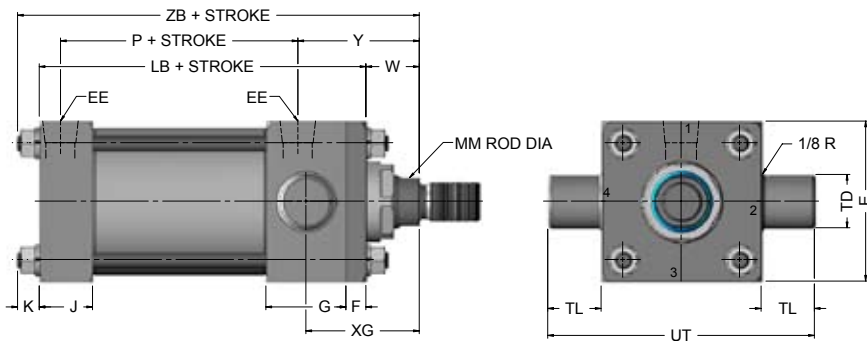

Cap Trunnion
Style ST5T2
(NFPA Style MT2)

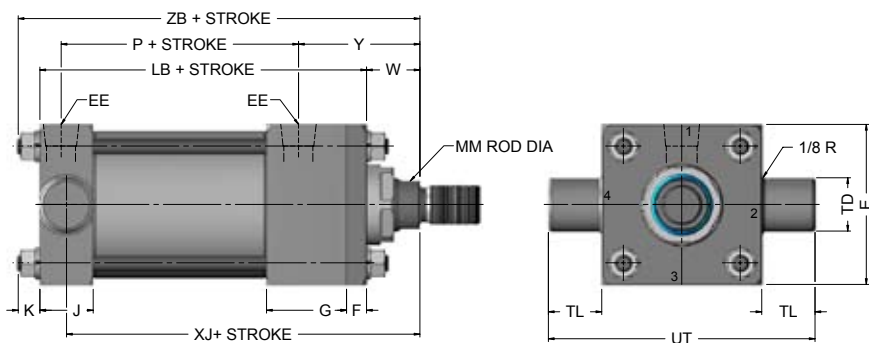

Intermediate Fixed Trunnion
Style ST5T4
(NFPA Style MT4)

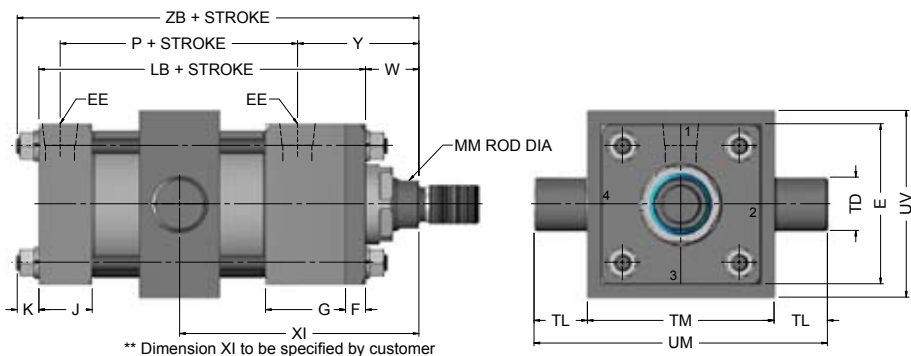

Rod End Dimensions—see table 2

Thread Style #2
(NFPA Style SM)
Small Male

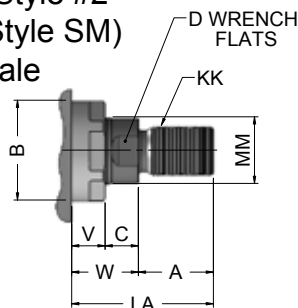

Thread Style #1
(NFPA Style IM)
Intermediate Male

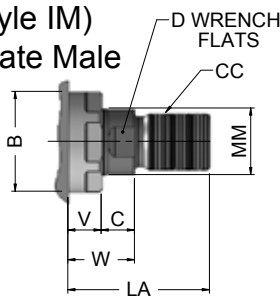

Thread Style #4
(NFPA Style SF)
Small Female

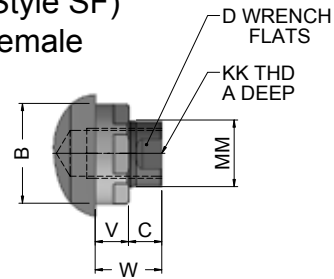

“Specials” Thread Style #X

To order, specify “Style #X” and give desired dimensions for CC or KK, A and LA. If otherwise special, furnish dimensional sketch.

A high strength rod end stud is supplied on thread style #2 through 1" diameter rods and on thread style #1 through 1" diameter rods. Larger sizes or special rod ends are cut threads. Style #2 rod ends are recommended where the workpiece is secured against the rod shoulder. When the workpiece is not shouldered, style 4 rod ends are recommended through 2" piston rod diameters and style #1 rod ends are recommended on larger diameters. Use style #4 for applications where female rod end threads are required. If rod end is not specified, style #2 will be supplied

ST5 SERIES

Medium Duty Hydraulic Cylinders

Trunnion Mountings
8" Bore Size

Table 1—Envelope and Mounting Dimensions- MT1, MT2 style

BORE	E	EE		F	G	J	K	+.000 -.001 TD	TL	UT	ADD STROKE	
		NPTF*	SAE**								LB	P
8	8 1/2	3/4	12	3/4	2	1 1/2	9/16	1.375	1 3/8	11 1/4	5 7/8	3 1/4

*NPTF ports will be furnished as standard unless SAE straight thread ports are specified.
** SAE straight thread ports are indicated by port number.

Table 2—Rod Dimensions - MT1, MT2 style

BORE	ROD SIZE	Thread Style		Rod Extensions and pilot dimensions								Add Stroke				
		STYLE #1	STYLE #2 & #4 KK	A	±.001 B	C	D	LA	NA	V	W	TT	XG	Y	XJ	ZB
8	1 3/8	1 1/4-12	1-14	1 5/8	1.998	5/8	1 1/8	2 1/2	1 5/16	1/4	7/8	4	2 5/8	2 13/16	6	7 5/16
	1 3/4	1 1/2-12	1 1/4-12	2	2.373	3/4	1 1/2	3 1/8	1 11/16	3/8	1 1/8	4	2 7/8	3 1/16	6 1/4	7 9/16
	std 2	1 3/4-12	1 1/2-12	2 1/4	2.623	7/8	1 11/16	3 1/2	1 5/16	3/8	1 1/4	4	3	3 3/16	6 3/8	7 11/16
	2 1/2	2 1/4-12	1 7/8-12	3	3.123	1	2 1/16	4 1/2	2 3/8	1/2	1 1/2	4	3 1/4	3 7/16	6 5/8	7 15/16
	3	2 3/4-12	2 1/4-12	3 1/2	3.748	1	2 5/8	5	2 7/8	1/2	1 1/2	5 1/2	3 1/4	3 7/16	6 5/8	7 15/16
	3 1/2	3 1/4-12	2 1/2-12	3 1/2	4.248	1	3	5	3 3/8	1/2	1 1/2	5 1/2	3 1/4	3 7/16	6 5/8	7 15/16
	4	3 3/4-12	3-12	4	4.748	1	3 3/8	5 1/2	3 7/8	1/2	1 1/2	5 1/2	3 1/4	3 7/16	6 5/8	7 15/16
	4 1/2	4 1/4-12	3 1/4-12	4 1/2	5.248	1	3 7/8	6	4 3/8	1/2	1 1/2	7	3 1/4	3 7/16	6 5/8	7 15/16
	5	4 3/4-12	3 1/2-12	5	5.748	1	4 1/4	6 1/2	4 7/8	1/2	1 1/2	7	3 1/4	3 7/16	6 5/8	7 15/16
	5 1/2	5 1/4-12	4-12	5 1/2	6.248	1	4 5/8	7	5 3/8	1/2	1 1/2	7	3 1/4	3 7/16	6 5/8	7 15/16

Table 3—Envelope and Mounting Dimensions

Table 1—Envelope and Mounting Dimensions - MT4 style

BORE	BD	E	EE		F	G	J	K	+.000 -.001 TD	TL	TM	UM	UV	STYLE MT4 MIN STROKE	ADD STROKE	
			NPTF*	SAE**											LB	P
8	2 1/2	8 1/2	3/4	12	3/4	2	1 1/2	9/16	1.375	1 3/8	9 3/4	12 1/2	9 1/2	7/8	5 7/8	3 1/4

*NPTF ports will be furnished as standard unless SAE straight thread ports are specified.
** SAE straight thread ports are indicated by port number.

Table 2—Rod Dimensions - MT4, style

BORE	ROD SIZE	Thread Style		Rod Extensions and pilot dimensions								Add Stroke			
		STYLE #1	STYLE #2 & #4 KK	A	±.001 B	C	D	LA	NA	V	W	TT	MIN** XI	Y	ZB
8	1 3/8	1 1/4-12	1-14	1 5/8	1.998	5/8	1 1/8	2 1/2	1 5/16	1/4	7/8	4	4 15/16	2 13/16	7 5/16
	1 3/4	1 1/2-12	1 1/4-12	2	2.373	3/4	1 1/2	3 1/8	1 11/16	3/8	1 1/8	4	5 3/16	3 1/16	7 9/16
	std 2	1 3/4-12	1 1/2-12	2 1/4	2.623	7/8	1 11/16	3 1/2	1 5/16	3/8	1 1/4	4	5 5/16	3 3/16	7 11/16
	2 1/2	2 1/4-12	1 7/8-12	3	3.123	1	2 1/16	4 1/2	2 3/8	1/2	1 1/2	4	5 9/16	3 7/16	7 15/16
	3	2 3/4-12	2 1/4-12	3 1/2	3.748	1	2 5/8	5	2 7/8	1/2	1 1/2	5 1/2	5 9/16	3 7/16	7 15/16
	3 1/2	3 1/4-12	2 1/2-12	3 1/2	4.248	1	3	5	3 3/8	1/2	1 1/2	5 1/2	5 9/16	3 7/16	7 15/16
	4	3 3/4-12	3-12	4	4.748	1	3 3/8	5 1/2	3 7/8	1/2	1 1/2	5 1/2	5 9/16	3 7/16	7 15/16
	4 1/2	4 1/4-12	3 1/4-12	4 1/2	5.248	1	3 7/8	6	4 3/8	1/2	1 1/2	7	5 9/16	3 7/16	7 15/16
	5	4 3/4-12	3 1/2-12	5	5.748	1	4 1/4	6 1/2	4 7/8	1/2	1 1/2	7	5 9/16	3 7/16	7 15/16
	5 1/2	5 1/4-12	4-12	5 1/2	6.248	1	4 5/8	7	5 3/8	1/2	1 1/2	7	5 9/16	3 7/16	7 15/16

** Dimension XI to be specified by customer

Table 3—Envelope and Mounting Dimensions

ST5 SERIES

Medium Duty Hydraulic Cylinders

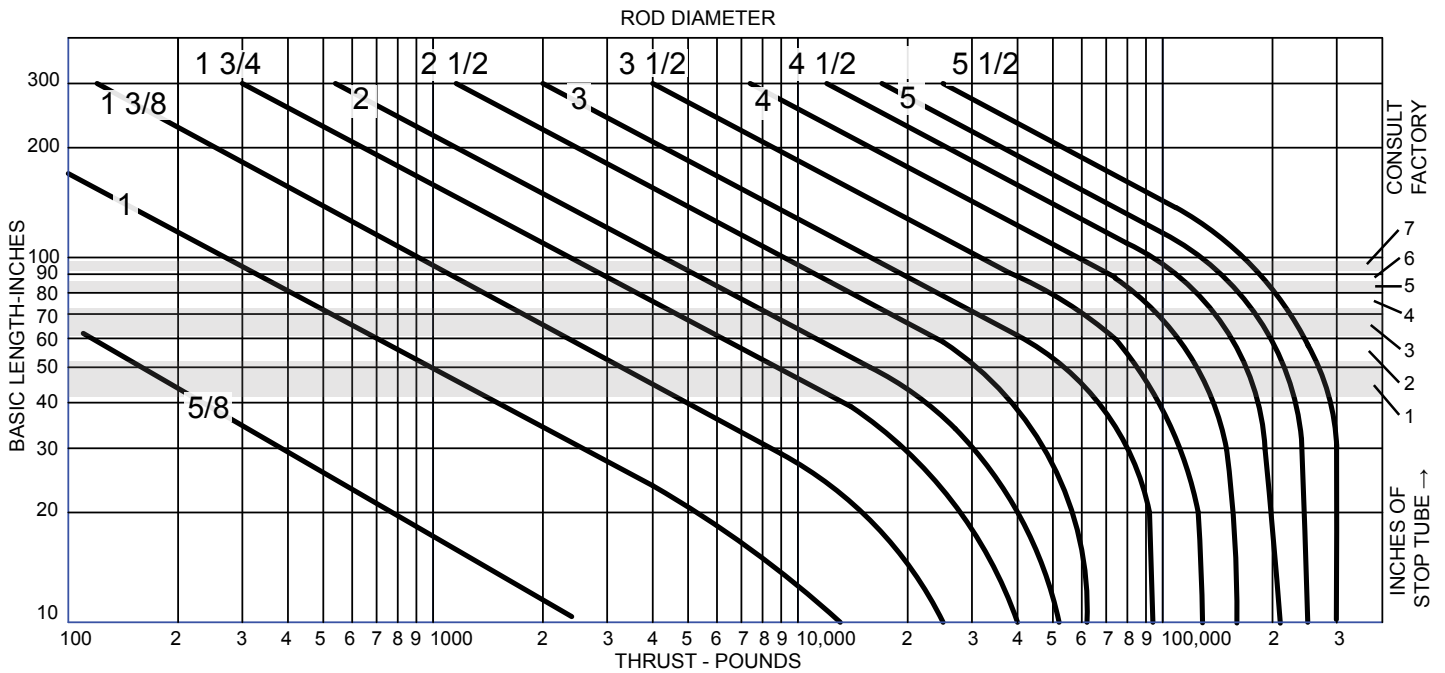

ROD SIZE SELECTION

To determine the minimum recommended piston rod dia for your application:

- 1) Determine the cylinder thrust using the force volume chart. (Page 21) (Thrust equals bore area multiplied by the operating pressure.)
- 2) Select from the diagram beside the type of mounting you will use.
- 3) Determine the basic length by multiplying the real stroke by the stroke factor.
- 4) Enter the graph along the values of "basic length" and "Thrust".

The stripe within which these lines intersect represents the minimum recommended piston rod diameter.

STOP TUBE SELECTION

Stop tubes are installed between the piston and the head on long stroke cylinders to reduce the load on the bearing. That, in turn, reduces bearing wear and tendency to buckle.

To determine if a stop tube is required and, if so, its length, first determine the "basic length" from the diagram. Step 1, 2 & 3 of The Rod Size Selection.

If the "basic length" is less than 40", no stop tube is needed. If it's over than 40", a one-inch stop tube is recommended for every 10" (or fraction thereof) over 40"

See Page 36 on Stop Tube Option and how to Order

MOUNTING STYLE		ROD END CONNECTION	STROKE FACTOR
Center line Mounting Centerline mounting places the mounting bolts in simple shear or simple tension so that the mechanism is protected from compound forces. Centerline mounting is a rigid mounting style and this requires accurate cylinder alignment to prevent damage to the cylinder working parts. Mountings are : MX1, MX2, MX3, MF1, MF2, ME3, ME4.		Fixed & Rigidly Guided	0.50
		Pivoted & Rigidly Guided	0.70
		Supported but not Rigidly Guided	2.00
		Unsupported	4.00
Pivot Mounting Pivot mounting is used when the cylinder must pivot during piston motion. Clevis and Trunnion mounts are two methods used to allow this motion. The Clevis end design locates the pivot point at the cap end of the cylinder. Trunnion mounting uses the head or the cap of the cylinder to allow it to pivot at any of the two locations. The Mountings are: MP1, MP2, MP4, MT1, MT2, MT4.	MT1 TRUNNION ON HEAD END	Pivoted & Rigidly Guided	1.00
	MT4 INTERMEDIATE TRUNNION	Pivoted & Rigidly Guided	1.50
	MT2 TRUNNION ON CAP END	Pivoted & Rigidly Guided	2.00
	MP1, MP2, MP4 CLEVIS ON CAP	Pivoted & Rigidly Guided	2.00

ST5 SERIES

Medium Duty Hydraulic Cylinders

Pressure Rating for ST5 series hydraulic cylinders vary by bore size and rod size as shown in table below. For pressure higher than those indicated, ST6 series Heavy Duty cylinders should be used.

Bore Size	Rod Size	Pressure Rating at 4:1 Design Factor (on Tensile)
1 1/2	5/8	2280
	1	2500
2	5/8	1235
	1	1925
	1 3/8	1925
2 1/2	5/8	775
	1	1550
	1 3/8	1550
	1 3/4	1550
3 1/4	1	1030
	1 3/8	1200
	1 3/4	1200
	2	1200
4	1	670
	1 3/8	845
	1 3/4	845
	2	845
	2 1/2	845
5	1	545
	1 3/8	700
	1 3/4	780
	2	780
	2 1/2	780
	2	780
	3 1/2	780
	4	780
6	1 3/8	500
	1 3/4	600
	2	660
	2 1/2	660
	2	660
	3 1/2	660
8	1 3/8	310
	1 3/4	400
	2	450
	2 1/2	630
	3	630
	3 1/2	630
	4	630
	4 1/2	630
	5	630
	5 1/2	630

Push Force and Displacement

Bore Size	piston Area	Cylinder Push Force in pounds at various Pressures					Displacement Per inch of stroke (Gallons)
		50	100	500	1000	1500	
1 1/2	1.767	88	177	885	1770	2655	.00765
2	3.14	157	314	1570	3140	4710	.0136
2 1/2	4.91	245	491	2455	4910	7365	.0213
3 1/4	8.30	415	830	4150	8300	12450	.0359
4	12.57	628	1257	6285	12570	18855	.0544
5	19.64	982	1964	9820	19640	29460	.0850
6	28.27	1414	2827	14135	28270	42405	.1224
8	50.27	2513	5027	25135	50270	75405	.2176

Deductions for Pull Force or Displacement

To determine Cylinder Pull Force or displacement, deduct the following force or displacement corresponding to rod size, from selected push Force or displacement corresponding to Bore size in table above

Rod Size	Rod Area	Piston Rod Diameter Force in pounds at various Pressures					Displacement Per inch of stroke (Gallons)
		50	100	500	1000	1500	
5/8	0.307	15	31	154	307	460	.0013
1	0.785	39	79	392	785	1177	.0034
1 3/8	1.490	75	149	745	1490	2235	.0065
1 3/4	2.410	121	241	1205	2410	3615	.0104
2	3.141	157	314	1570	3141	4711	.0136
2 1/2	4.910	245	491	2455	4910	7365	.0213
3	7.070	354	707	3535	7070	10605	.0306
3 1/2	9.620	481	962	4810	9620	14430	.0416
4	12.57	628	1257	6285	12570	23355	.0544
4 1/2	15.90	795	1590	7950	15900	23850	.0688
5	19.64	982	1964	9820	19640	23460	.0850
5 1/2	23.76	1188	2376	11880	23760	35640	.1028

Area Extended stroke Push : $AE = .7854 BD^2$
 Area Retracted stroke Pull : $AR = (.7854 BD^2 - .7854 RD^2)$
 Cylinder Push Force Formula : $FE = P \times AE$
 Cylinder Pull Force Formula : $FR = P \times AR$
 Cylinder Volume (Gallons) : $G = \frac{\text{Net area (in}^2\text{)} \times \text{Stroke (in)}}{231}$

FE= Force Extended Stroke
 FR= Force Retracted Stroke
 P= Working Pressure
 BD= Bore Diameter
 RD= Rod Diameter

ST5 SERIES

Medium Duty Hydraulic Cylinders

NFPA CLEVIS BRACKET

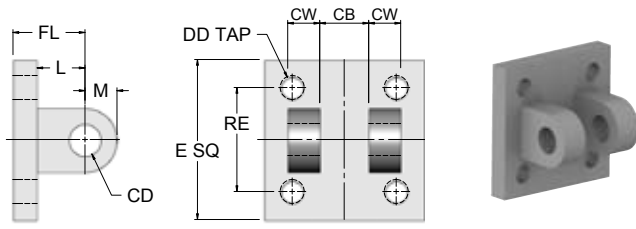

Part #	CB	CD PIN DIA.	CW	DD	E	FL	L	M	RE
CB-05	.765	1/2	1/2	3/8-24	2 1/2	1 1/8	3/4	1/2	1 5/8
CB-07	1.265	3/4	5/8	1/2-20	3 1/2	1 7/8	1 1/4	3/4	2 9/16
CB-10	1.515	1	3/4	5/8-18	4 1/2	2 1/4	1 1/2	1	3 1/4
CB-13	2.032	1 3/8	1	5/8-18	5	3	2 1/8	1 3/8	3 13/16
CB-17	2.531	1 3/4	1 1/4	7/8-14	6 1/2	3 1/8	2 1/4	1 3/4	4 15/16
CB-20	2.531	2	1 1/4	1-14	7 1/2	3 1/2	2 1/2	2	5 3/4
CB-25	3.032	2 1/2	1 1/2	1 1/8-12	8 1/2	4	3	2 1/2	6 19/32
CB-30	3.032	3	1 1/2	1 1/4-12	9 1/2	4 1/4	3 1/4	2 3/4	7 1/2
CB-35	4.032	3 1/2	2	1 3/4-12	12 5/8	5 11/16	4	3 1/2	9 5/8
CB-40	4.532	4	2 1/4	2-12	14 7/8	6 7/16	4 1/2	4	11 1/2

NFPA EYE BRACKET

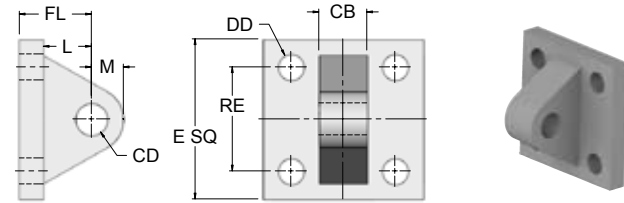

Part #	CB	CD PIN DIA.	DD	E	FL	L	M	RE
EB-05	.750	1/2	13/32	2 1/2	1 1/8	3/4	1/2	1 5/8
EB-07	1.25	3/4	17/32	3 1/2	1 7/8	1 1/4	3/4	2 9/16
EB-10H	1.50	1	21/32	4 1/2	2 3/8	1 1/2	1	3 1/4
EB-13	2.00	1 3/8	21/32	5	3	2 1/8	1 3/8	3 13/16
EB-17H	2.50	1 3/4	29/32	6 1/2	3 3/8	2 1/4	1 3/4	4 15/16
EB-20H	2.50	2	1 1/16	7 1/2	4	2 1/2	2	5 3/4
EB-25H	3.00	2 1/2	1 3/16	8 1/2	4 3/4	3	2 1/2	6 19/32
EB-30H	3.00	3	1 5/16	9 1/2	5 1/4	3 1/4	3	7 1/2
EB-35	4.00	3 1/2	1 13/16	12 5/8	5 11/16	4	3 1/2	9 5/8
EB-40	4.50	4	2 1/16	14 7/8	6 7/16	4 1/2	4	11 1/2

NFPA ROD CLEVIS

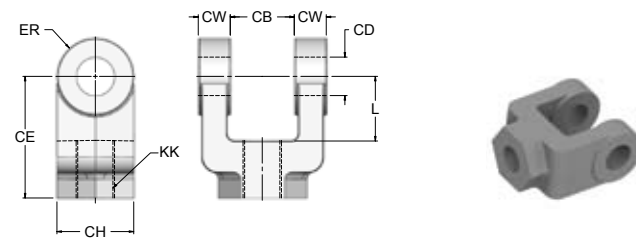

Part #	CB	CD PIN DIA.	CE	CH HEX.	CW	ER	KK	L
RC-05	.765	1/2	1 1/2	1	1/2	1/2	7/16-20	3/4
RC-07	1.265	3/4	2 3/8	1 1/4	5/8	3/4	3/4-16	1 1/4
RC-07H	1.265	3/4	2 1/8	1 3/8	5/8	3/4	3/4-16	1
RC-10	1.515	1	3 1/8	1 1/2	3/4	1	1-14	1 1/2
RC-10H	1.515	1	2 15/16	1 1/2	3/4	1	1-14	1 5/16
RC-13	2.032	1 3/8	4 1/8	2	1	1 3/8	1 1/4-12	2 1/8
RC-13H	2.032	1 3/8	3 3/4	2	1	1 3/8	1 1/4-12	1 3/4
RC-17	2.531	1 3/4	4 1/2	2 3/8	1 1/4	1 3/4	1 1/2-12	2 1/4
RC-20	2.531	2	5 1/2	2 15/16	1 1/4	2	1 7/8-12	2 1/2
RC-25	3.032	2 1/2	6 1/2	3 1/2	1 1/2	2 1/2	2 1/4-12	3
RC-30	3.032	3	6 3/4	3 7/8	1 1/2	2 3/4	2 1/2-12	3 1/4
RC-30H	3.032	3	6 3/4	3 7/8	1 1/2	3	2 1/2-12	3 1/4
RC-35	4.032	3 1/2	8 1/2	5	2	3 1/2	3 1/4-12	4
RC-35H	4.032	3 1/2	7 3/4	5	2	3 1/2	3 1/4-12	4 1/4
RC-40	4.532	4	10	6 1/8	2 1/4	4	4-12	4 1/2

NFPA ROD EYE

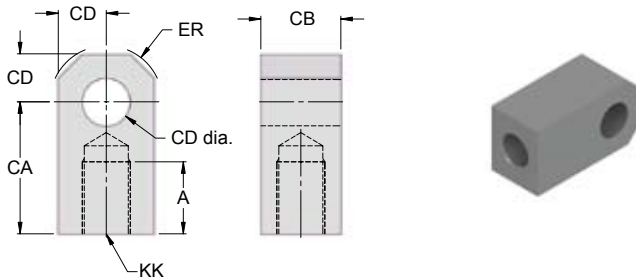

Part #	A	CA	CB	CD PIN DIA.	ER	KK
RE-05	3/4	1 1/2	3/4	1/2	5/8	7/16-20
RE-07	1 1/8	2 1/16	1 1/4	3/4	7/8	3/4-16
RE-10	1 5/8	2 13/16	1 1/2	1	1 3/16	1-14
RE-10H	1 1/8	2 3/8	1 1/2	1	1 7/16	1-14
RE-13	2	3 7/16	2	1 3/8	1 9/16	1 1/4-12
RE-17	2 1/4	4	2 1/2	1 3/4	2	1 1/2-12
RE-20	3	5	2 1/2	2	2 1/2	1 7/8-12
RE-20H	2 1/4	4 3/8	2 1/2	2	2 7/8	1 3/4-12
RE-25	3 1/2	6 13/16	3	2 1/2	2 13/16	2 1/4-12
RE-30	3 1/2	6 1/8	3	3	3 1/4	2 1/2-12
RE-30H	3 5/8	6 1/2	3 1/2	3	3 1/4	2 3/4-12
RE-35	4 1/2	7 5/8	4	3 1/2	3 7/8	3 1/4-12
RE-35H	5	7 5/8	4	3 1/2	3 7/8	3 1/2-12
RE-40	5 1/2	9 1/8	4 1/2	4	4 7/16	4-12
RE-40H	5 3/4	9 1/8	5	4	4 7/16	4 1/2-12

NFPA PIN

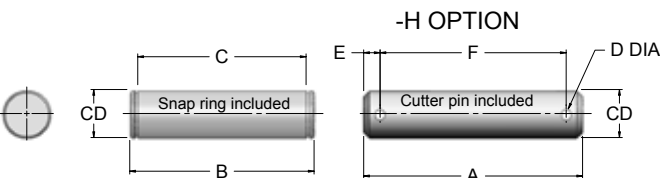

Part #	CD	A	B	C	D	E	F
P-05	1/2	2.281	2.094	1.875	0.106	0.172	1.938
P-07	3/4	3.094	2.875	2.625	0.140	0.188	2.719
P-10	1	3.594	3.375	3.125	0.140	0.188	3.219
P-13	1 3/8	4.656	4.485	4.187	0.173	0.203	4.25
P-17	1 3/4	5.656	5.547	5.188	0.173	0.219	5.250
P-20	2	5.719	5.547	5.188	0.204	0.234	5.281
P-25	2 1/2	2.360	6.625	6.188	0.219	0.219	6.313
P-30	3	2.838	6.780	6.250	0.250	0.250	6.344
P-35	3 1/2	3.316	8.845	8.125	0.312	0.282	8.406
P-40	4	3.792	9.845	9.125	0.312	0.282	9.969

ST5 SERIES

Medium Duty Hydraulic Cylinders

Cylinder Special Rod End

Style #5 Piston Rod End Flange

Rod End Flange Coupling For series ST5, ST6 Hydraulic and ST3 and ST4 Pneumatic

- Simplifies alignment
- Reduces assembly time
- Allows full rated hydraulic pressure in push and pull directions
- Available in 5/8" through 5.5" piston rod diameters

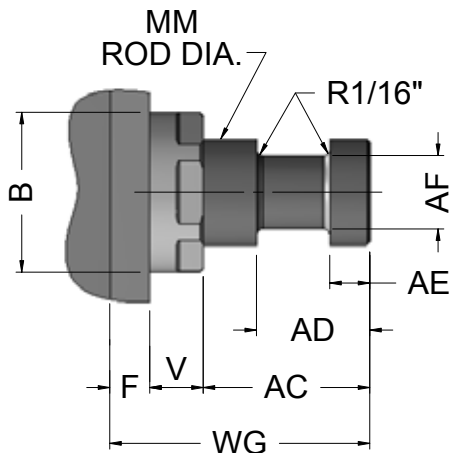

Style #6 Piston Rod End Plain

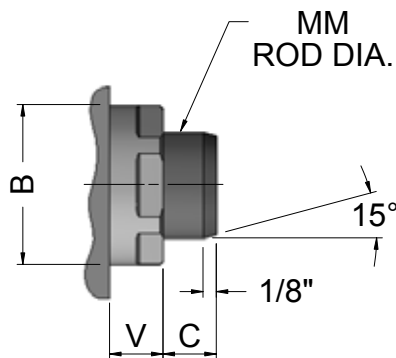

BORE	ROD SIZE	MM								
			±.001 B	C	AC	AD	AE	AF	V	WG
1 1/2	std	5/8	1.123	3/8	1 1/8	5/8	1/4	3/8	1/4	1 3/4
		1	1.498	1/2	1 1/2	15/16	3/8	11/16	1/2	2 3/8
2	std	5/8	1.123	3/8	1 1/8	5/8	1/4	3/8	1/4	1 3/4
		1	1.498	1/2	1 1/2	15/16	3/8	11/16	1/2	2 3/8
		1 3/8	1.998	5/8	1 3/4	1 1/16	3/8	7/8	5/8	2 3/4
2.5		5/8	1.123	3/8	1 1/8	5/8	1/4	3/8	1/4	1 3/4
	std	1	1.498	1/2	1 1/2	15/16	3/8	11/16	1/2	2 3/8
		1 3/8	1.998	5/8	1 3/4	1 1/16	3/8	7/8	5/8	2 3/4
		1 3/4	2.373	3/4	2	1 5/16	1/2	1 1/8	3/4	3 1/8
3.25	std	1	1.498	1/2	1 1/2	15/16	3/8	11/16	1/2	2 3/8
		1 3/8	1.998	5/8	1 3/4	1 1/16	3/8	7/8	5/8	2 3/4
		1 3/4	2.373	3/4	2	1 5/16	1/2	1 1/8	3/4	3 1/8
		2	2.623	7/8	2 5/8	1 11/16	5/8	1 3/8	1/2	3 3/4
4		1	1.498	1/2	1 1/2	15/16	3/8	11/16	1/2	2 3/8
	std	1 3/8	1.998	5/8	1 3/4	1 1/16	3/8	7/8	5/8	2 3/4
		1 3/4	2.373	3/4	2	1 5/16	1/2	1 1/8	3/4	3 1/8
		2	2.623	7/8	2 5/8	1 11/16	5/8	1 3/8	1/2	3 3/4
		2 1/2	3.123	1	3 1/4	1 15/16	3/4	1 3/4	5/8	4 1/2
5		1	1.498	1/2	1 1/2	15/16	3/8	11/16	1/2	2 3/8
		1 3/8	1.998	5/8	1 3/4	1 1/16	3/8	7/8	5/8	2 3/4
	std	1 3/4	2.373	3/4	2	1 5/16	1/2	1 1/8	3/4	3 1/8
		2	2.623	7/8	2 5/8	1 11/16	5/8	1 3/8	1/2	3 3/4
		2 1/2	3.123	1	3 1/4	1 15/16	3/4	1 3/4	5/8	4 1/2
		3	3.748	1	3 5/8	2 7/16	7/8	2 1/4	5/8	4 7/8
		3 1/2	4.248	1	4 3/8	2 11/16	1	2 1/2	5/8	5 5/8
6		1 3/8	1.998	5/8	1 3/4	1 1/16	3/8	7/8	5/8	2 3/4
	std	1 3/4	2.373	3/4	2	1 5/16	1/2	1 1/8	3/4	3 1/8
		2	2.623	7/8	2 5/8	1 11/16	5/8	1 3/8	1/2	3 3/4
		2 1/2	3.123	1	3 1/4	1 15/16	3/4	1 3/4	5/8	4 1/2
		3	3.748	1	3 5/8	2 7/16	7/8	2 1/4	5/8	4 7/8
		3 1/2	4.248	1	4 3/8	2 11/16	1	2 1/2	5/8	5 5/8
		4	4.748	1	4 1/2	2 11/16	1	3	1/2	5 3/4
8		1 3/8	1.998	5/8	1 3/4	1 1/16	3/8	7/8	5/8	2 3/4
		1 3/4	2.373	3/4	2	1 5/16	1/2	1 1/8	3/4	3 1/8
	std	2	2.623	7/8	2 5/8	1 11/16	5/8	1 3/8	1/2	3 3/4
		2 1/2	3.123	1	3 1/4	1 15/16	3/4	1 3/4	5/8	4 1/2
		3	3.748	1	3 5/8	2 7/16	7/8	2 1/4	5/8	4 7/8
		3 1/2	4.248	1	4 3/8	2 11/16	1	2 1/2	5/8	5 5/8
		4	4.748	1	4 1/2	2 11/16	1	3	1/2	5 3/4
		4 1/2	5.248	1	5 1/4	3 3/16	1 1/2	3 1/2	1/2	6 1/2
		5	5.748	1	5 3/8	3 3/16	1 1/2	3 7/8	1/2	6 5/8
		5 1/2	6.248	1	6 1/4	3 15/16	1 7/8	4 3/8	1/2	7 1/2

**Spherical Bearing Mount
 Style SB**

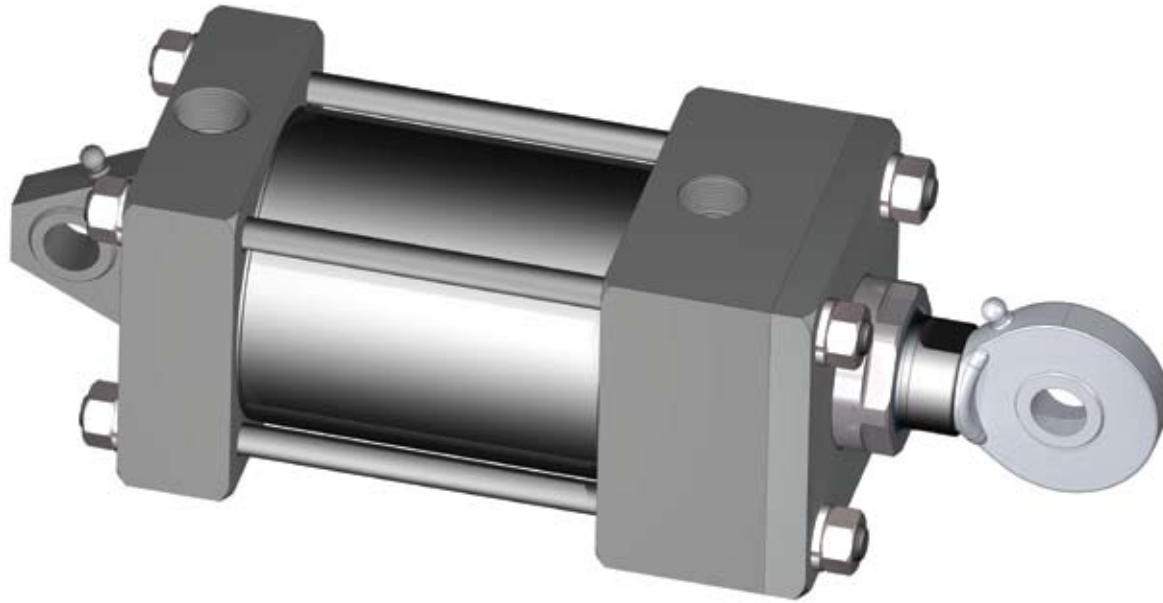

Mounting Information
 Head End Mounting

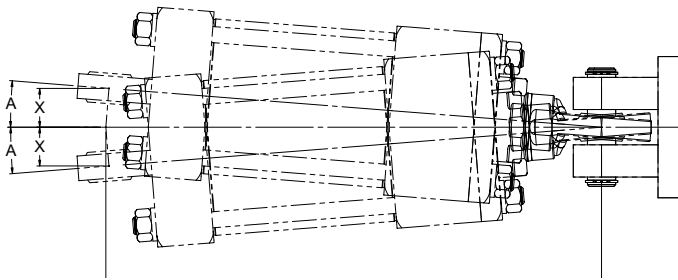

Mounting Information
 Cap End Mounting

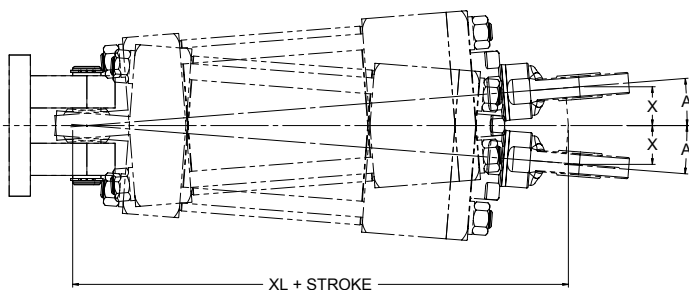

Table 1 — Dimensions

Recommended maximum swivel angle on each side of the cylinder centerline.

Bore	Head End Mount		Cap End Mount	
	Angle A	Tan. of A	Angle A	Tan. of A
1 1/2	2 1/2	0.035	2 1/2	0.035
2	2 1/2	0.044	4 1/2	0.079
2 1/2	2 1/2	0.044	4 1/2	0.079
3 1/4	3 1/2	0.052	3 1/2	0.052
4	2 1/2	0.044	3 1/2	0.052
5	3 1/2	0.052	3 1/2	0.052
6	3 1/2	0.052	3 1/2	0.052

Note: Dimension X is the maximum off center mounting of the cylinder. To Determine dimension X for various stroke lengths multiply the distance between pivot pin holes by tangent of angle A. For extended position use X = XL times 2X stroke.

ST5 SERIES

Medium Duty Hydraulic Cylinders

Spherical Bearing Mount
Style SB
1 1/2 to 8" Bore Sizes

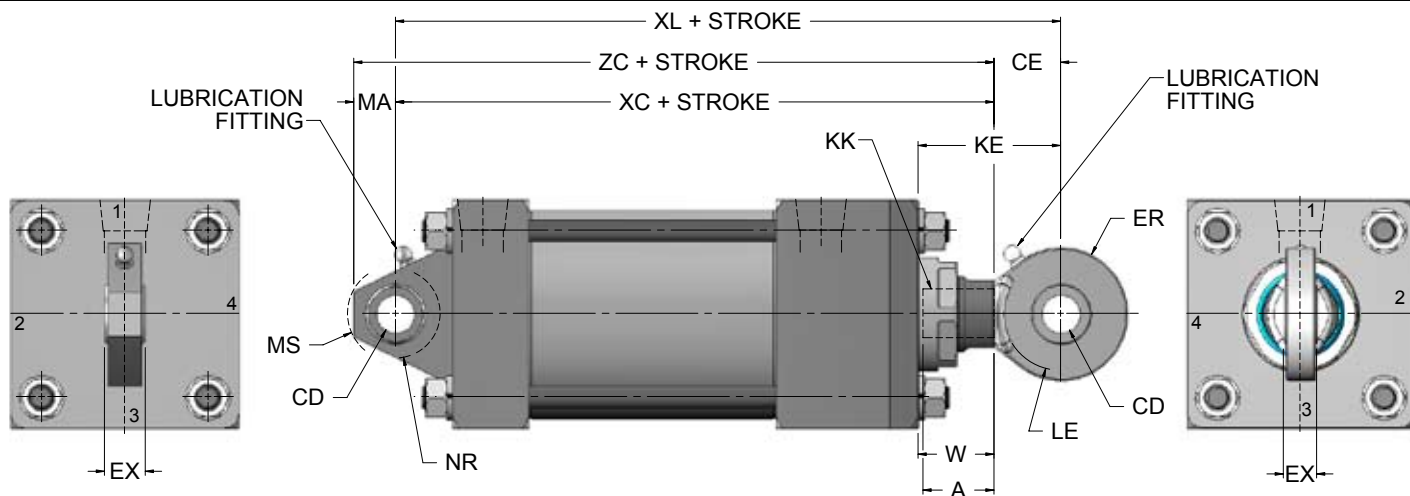

BORE	ROD SIZE	Thread Style		Add Stroke							CD*	CE	ER	EX	LE	MA	MS	NR	Max Oper. PSI	
		STYLE #4 KK	STYLE #7 KK	A	W	XC	XL	ZC	KE	ST4									ST5	
1 1/2	std	5/8	7/16-20	-	3/4	5/8	5 3/8	6 1/4	6 1/8	1 1/2	-.0005	7/8	13/16	7/16	3/4	3/4	15/16	5/8	250	1750
		1	-	7/16-20	3/4	1	5 3/4	6 5/8	6 1/2	1 7/8	.5000									
2	std	5/8	7/16-20	-	3/4	5/8	5 3/8	6 1/4	6 1/8	1 1/2	-.0005	7/8	13/16	7/16	3/4	3/4	15/16	5/8	250	980
		1	-	7/16-20	3/4	1	5 3/4	6 5/8	6 1/2	1 7/8										
		1 3/8	-	7/16-20	3/4	1 1/4	6	6 7/8	6 3/4	2 1/8	.5000									
2.5		5/8	7/16-20	-	3/4	5/8	5 3/8	6 1/4	6 1/8	1 1/2										
	std	1	-	7/16-20	3/4	1	5 3/4	6 5/8	6 1/2	1 7/8	-.0005	7/8	13/16	7/16	3/4	3/4	15/16	5/8	250	630
		1 3/8	-	7/16-20	3/4	1 1/4	6	6 7/8	6 3/4	2 1/8	.5000									
		1 3/4	-	7/16-20	3/4	1 1/2	6 3/8	7 1/4	7 1/8	2 3/8										
3.25	std	1	3/4-16	-	1 1/8	3/4	6 7/8	8 1/8	7 7/8	2	-.0005	1 1/4	1 1/8	21/32	11/16	1	1 3/8	1	250	830
		1 3/8	-	3/4-16	1 1/8	1	7 1/8	8 3/8	8 1/8	2 1/4	.7500									
		1 3/4	-	3/4-16	1 1/8	1 1/4	7 3/8	8 5/8	8 3/8	2 1/2										
		2	-	3/4-16	1 1/8	1 3/8	7 1/2	8 3/4	8 1/2	2 5/8										
4		1	3/4-16	-	1 1/8	5/8	6 7/8	8 1/8	7 7/8	2										
	std	1 3/8	-	3/4-16	1 1/8	1	7 1/8	8 3/8	8 1/8	2 1/4	-.0005	1 1/4	1 1/8	21/32	1 1/16	1	1 3/8	1	250	550
		1 3/4	-	3/4-16	1 1/8	1 1/4	7 3/8	8 5/8	8 3/8	2 1/2	.7500									
		2	-	3/4-16	1 1/8	1 3/8	7 1/2	8 3/4	8 1/2	2 5/8										
		2 1/2	-	3/4-16	1 1/8	1 5/8	7 3/4	9	8 3/4	2 7/8										
5		1	3/4-16	-	1 1/8	3/4	7 1/8	8 3/8	8 1/8	2										
		1 3/8	-	3/4-16	1 1/8	1	7 3/8	8 5/8	8 3/8	2 1/4										
	std	1 3/4	-	3/4-16	1 1/8	1 1/4	7 5/8	8 7/8	8 5/8	2 1/2	-.0005	1 1/4	1 1/8	21/32	1 1/16	1	1 3/8	1	250	350
		2	-	3/4-16	1 1/8	1 3/8	7 3/4	9	8 3/4	2 5/8	.7500									
		2 1/2	-	3/4-16	1 1/8	1 5/8	8	9 1/4	9	2 7/8										
		3	-	3/4-16	1 1/8	1 5/8	8	9 1/4	9	2 7/8										
6		1 3/8	1-14	-	1 5/8	7/8	8 1/8	10	9 3/8	2 3/4										
	std	1 3/4	-	1-14	1 5/8	1 1/8	8 3/8	10 1/4	9 5/8	3										
		2	-	1-14	1 5/8	1 1/4	8 1/2	10 3/8	9 3/4	3 1/8										
		2 1/2	-	1-14	1 5/8	1 1/2	8 3/4	10 5/8	10	3 3/8	-.0005	1 7/8	1 1/4	7/8	1 7/16	1 1/4	1 11/16	1 1/4	250	440
		3	-	1-14	1 5/8	1 1/2	8 3/4	10 5/8	10	3 3/8	1.0000									
		3 1/2	-	1-14	1 5/8	1 1/2	8 3/4	10 5/8	10	3 3/8										
8		1 3/8	1-14	-	1 5/8	7/8	8 1/4	10 1/8	9 1/2	2 3/4										
	std	1 3/4	-	1-14	1 5/8	1 1/8	8 1/2	10 3/8	9 3/4	3										
		2	-	1-14	1 5/8	1 1/4	8 5/8	10 1/2	9 7/8	3 1/8										
		2 1/2	-	1-14	1 5/8	1 1/2	8 7/8	10 3/4	10 1/8	3 3/8										
		3	-	1-14	1 5/8	1 1/2	8 7/8	10 3/4	10 1/8	3 3/8	-.0005	1 7/8	1 1/4	7/8	1 7/16	1 1/4	1 11/16	1 1/4	250	250
		3 1/2	-	1-14	1 5/8	1 1/2	8 7/8	10 3/4	10 1/8	3 3/8	1.0000									
		4	-	1-14	1 5/8	1 1/2	8 7/8	10 3/4	10 1/8	3 3/8										
		4 1/2	-	1-14	1 5/8	1 1/2	8 7/8	10 3/4	10 1/8	3 3/8										

NFPA SPHERICAL ROD EYE

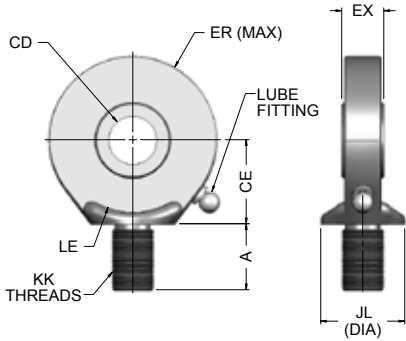

Bore Size	Part #	CD	A	CE	EX	ER	LE	KK	JL	LOAD
1 1/2, 2 & 2 1/2	RES-05	.5000 ⁻⁰⁰⁰⁵	11/16	7/8	7/16	13/16	3/4	7/16-20	7/8	2644
3 1/4, 4 & 5	RES-07	.7500 ⁻⁰⁰⁰⁵	1	1 1/4	21/32	1 1/8	1 1/16	3/4-16	1 5/16	9441
6 & 8	RES-10	1.0000 ⁻⁰⁰⁰⁵	1 1/2	1 7/8	7/8	1 1/4	1 7/16	1-14	1 1/2	16860
10	RES-13	1.3750 ⁻⁰⁰⁰⁵	2	2 1/8	1 3/16	1 11/16	1 7/8	1 1/4-12	2	28562
12	RES-17	1.7500 ⁻⁰⁰⁰⁵	2 1/8	2 1/2	1 17/32	2 1/16	2 1/8	1 1/2-12	2 1/4	43005
14	RES-20	2.000 ⁻⁰⁰⁰⁵	2 7/8	2 3/4	1 3/4	2 1/2	2 1/2	1 7/8-12	2 3/4	70193

NFPA SPHERICAL PIVOT PIN

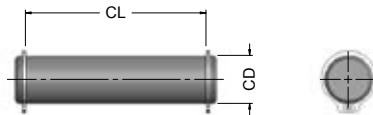

Bore Size	Part #	CD	CL	LOAD
1 1/2, 2 & 2 1/2	PS-05	.5000 ⁻⁰⁰⁰⁴	1 9/16	8600
3 1/4, 4 & 5	PS-07	.7500 ⁻⁰⁰⁰⁵	2 1/32	19300
6 & 8	PS-10	1.0000 ⁻⁰⁰⁰⁵	2 1/2	34300
10	PS-13	1.3750 ⁻⁰⁰⁰⁶	3 5/16	65000
12	PS-17	1.7500 ⁻⁰⁰⁰⁶	4 7/32	105200
14	PS-20	2.000 ⁻⁰⁰⁰⁷	4 15/16	137400

NFPA SPHERICAL CLEVIS BRACKET

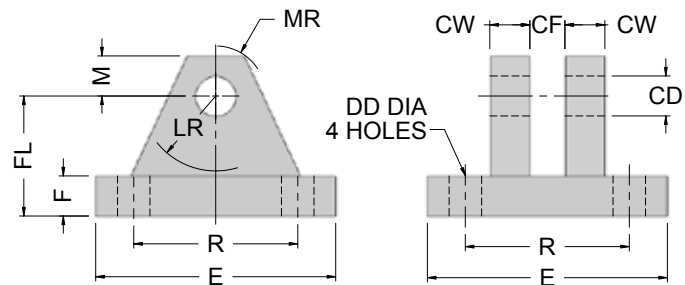

Bore Size	Part #	CD	CF	CW	DD	E	F	FL	LR	M	MR	R	LOAD
1 1/2, 2 & 2 1/2	CBS-05	1/2 ^{+004/+002}	7/16	1/2	13/32	3	1/2	1 1/2	15/16	1/2	5/8	2.05	5770
3 1/4, 4 & 5	CBS-07	3/4 ^{+004/+002}	21/32	5/8	17/32	3 3/4	5/8	2	1 3/8	7/8	1	2.76	9450
6 & 8	CBS-10	1 ^{+004/+002}	7/8	3/4	17/32	5 1/2	3/4	2 1/2	1 11/16	1	1 3/16	4.10	14300
10	CBS-13	1 3/8 ^{+004/+002}	1 3/16	1	21/32	6 1/2	7/8	3 1/2	2 7/16	1 3/8	1 5/8	4.95	20322
12	CBS-17	1 3/4 ^{+004/+002}	1 17/32	1 1/4	29/32	8 1/2	1 1/4	4 1/2	2 7/8	1 3/4	2 1/16	6.58	37800
14	CBS-20	2 ^{+004/+002}	1 3/4	1 1/2	29/32	10 5/8	1 1/2	5 1/2	3 5/16	2	2 3/8	7.92	50375

ST5 SERIES

Medium Duty Hydraulic Cylinders

Thread Extension

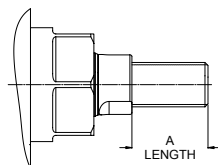

Option code A

Piston Rod Thread Extension can be ordered over standard. To order add option code **A=()** and specify "A" length.

Rod Extension

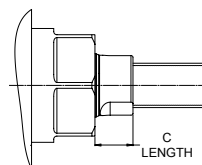

Option code C

Piston Rod Extension can be order over standard. To order add option code **C=()** and specify "C" length

Port & Adjustable Cushion Location

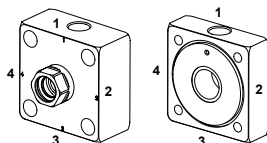

Option code N() C()

Specify optional location, N11 C22 default

Magnetic Piston & Aluminum Tubing

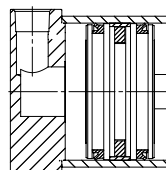

Option Code T2

When position sensing of the cylinder is required, a Magnetic Ring Must be added. The Magnetic ring is placed at the center of the piston under the wear band. The magnetic band will create a magnetic field which will actuate the sensor. Option code **T2. Must be used with aluminum tubing - Low Pressure**

Electroless Nickel

Option Code FN

The properties of Electroless nickel contribute to the multitude of uses. The coating provides an attractive finish, while exhibiting high abrasion and corrosion resistance. Its ability to uniform coat blind holes, threads, internal surfaces and sharp edges contributes to its effectiveness. It has a very high bonding strength to the base metal. Coating can be done on aluminum, steel, cast iron, etc

StarNite Head and Cap

Option Code FM

This option will give you a black finish resistant to corrosion for outside applications or caustic washdown, and really hard to scratch due to the hardness of the part after the chemical process of the StarNite. See page 4 for more detail. Tubing, tie rods and rod are already process with StarNite.

Viton Seals

Option code LV & PV

Fluorocarbon will be chosen for higher temperature range from 200°F to 400°F (200°C)

For Chemical resistance our standard Blue Seals will Outstand Viton by far in most chemical Application and wear resistance. Resists most wash down application.

LV : U-cup Seals in Fluorocarbon With Teflon Backup

PV : Polypack Ucup/oring loaded in Fluorocarbon

Metallic Rod Scraper

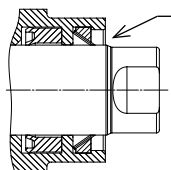

Option A1

Aggressively Scrapes the exposed portion of the piston rod free of weld splatter, paint spray, abrasive powders or many other foreign materials that could damage the rod seal.

Air Bleeder

Option B1, B2, B3, B4

An air bleed may be ordered at either or both ends of the cylinder as an option. To provide for maximum bleeding of air from the cylinder, STARCYL places its air bleeds in the end caps to bleed air from the tube/head or tube/cap juncture. The air is bleed from the cylinder by backing out the straight thread metallic seal plug to allow air to pass by the threads. When air bubbles stop and oil starts to flow, retighten plug. It is recommended that bleeding be done with pressure on the opposite end of the cylinder so that the bleed plug is not subjected to pump pressure when being backed out. Air bleeds should always be positioned at the highest point of the cylinder tube. Please specify positions of air bleeds by position number.

Chrome Rod Or Nitrotec Rod

Option Code R2 or R3

We still can supply old technology, for that matter you can request Chrome Rod (R2) Or Nitrotec Rod (R3).

END OF STROKE SENSOR

Option Code G1() & H1()

GO Switches are simple and built to last. With only one moving part and no metal-to-metal contact forcing it to move, there is nothing to wear out!

Must Indicate Position. Ex : G3 switch will be in position 3

Options Available

- Explosion Proof
- SPDT or DPDT
- HiTemp™ to 400°F
- SubSea™ Submersible
- Hermetically Sealed
- High Pressure to 10,000 psi
- English or metric threads



Option Code G1



Option Code H1

How it Works

When the ferrous cushion of a cylinder enters the sensing area of the switch, it attracts the primary magnet, which pulls the connecting rod forward. As a result, the common contact snaps to its operated position, closing the other contact circuit. When the target is removed the common contact automatically returns to its original unoperated position.

Stop Tube Design

Drawing A
Cushion design

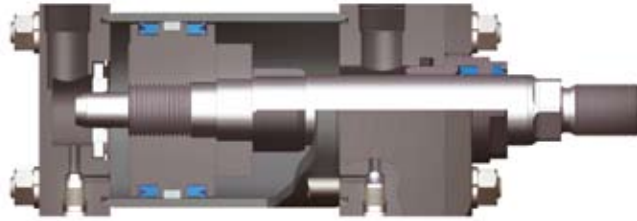

Drawing B
Non Cushion design

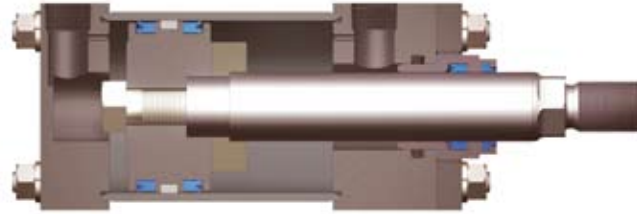

Stop Tube

Option Code **ST()** Enhances the transverse load carrying capability of a long stroke cylinder by increasing the distance between the piston and the rod bearing at full extension when placed on head end. Ideal for applications requiring longer strokes or where additional rod stability is desired. Specify stop tube length when ordering.

How To Order Stop Tube option

ex: ST5-3.25x60x1.38-ST4-N11C00 is a 3.25" bore with 60" Net stroke and a dual piston stop tube of 4" long, for a total gross stroke of 64" (must be used to calculate overall length "LB").

Linear Alignment Couplers

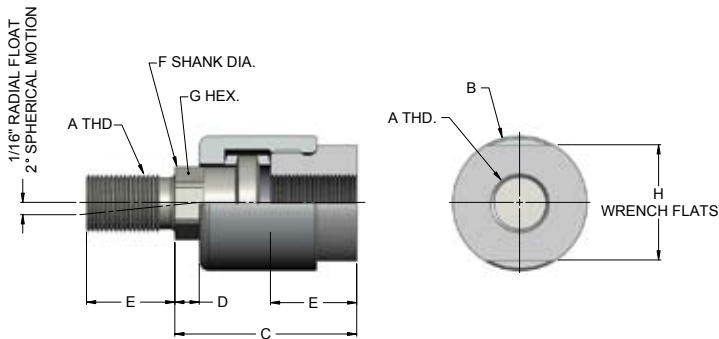

Star cyl's linear alignment couplers extend the bearing and seal life of your cylinders. Our couplers prevent binding and erratic movement that misalignment causes, which eventually wears down your cylinders. Not only do Starcyl couplers work equally well in "push" and "pull" applications, but they allow a greater tolerance between the cylinder center line and the mating member.

* Use jam nut to lock coupler to rod when used with full diameter threads.

Part #	A	B	C	D	E	F	G	H	MAX PULL AT YIELD
AC-250F	1/4-28	7/8	1 1/4	1/4	5/8	0.245	3/16	13/16	6000
AC-312F	5/16-24	7/8	1 1/4	1/4	5/8	0.308	1/4	13/16	8300
AC-375C	3/8-16	7/8	1 1/4	1/4	5/8	0.369	5/16	13/16	5000
AC-375F	3/8-24	7/8	1 1/4	1/4	5/8	0.370	5/16	13/16	8300
AC-437F	7/16-20	1 1/4	2	1/2	3/4	5/8	9/16	1 1/8	10000
AC-500C	1/2-13	1 1/4	2	1/2	3/4	5/8	9/16	1 1/8	14000
AC-500F	1/2-20	1 1/4	2	1/2	3/4	5/8	9/16	1 1/8	14000
AC-625F	5/8-18	1 1/4	2	1/2	3/4	5/8	1/2	1 1/8	14000
AC-750C	3/4-10	1 3/4	2 5/16	5/16	1 1/8	31/32	7/8	1 1/2	34000
AC-750F	3/4-16	1 3/4	2 5/16	5/16	1 1/8	31/32	7/8	1 1/2	34000
AC-875F	7/8-14	1 3/4	2 5/16	5/16	1 1/8	31/32	7/8	1 1/2	34000
AC-1000C	1-8	2 1/2	2 15/16	1/2	1 5/8	1 3/8	1 1/4	2 1/4	64000
AC-1000F	1-14	2 1/2	2 15/16	1/2	1 5/8	1 3/8	1 1/4	2 1/4	64000
AC-1250F	1 1/4-12	2 1/2	2 15/16	1/2	1 5/8	1 3/8	1 1/4	2 1/4	64000
AC-1375F	1 3/8-12	2 1/2	2 15/16	1/2	1 5/8	1 3/8	1 1/4	2 1/4	64000
AC-1500F	1 1/2-12	3 1/4	4 3/8	13/16	2 1/4	1 3/4	1 1/2	3	134000
AC-1750F	1 3/4-12	3 1/4	4 3/8	13/16	2 1/4	1 3/4	1 1/2	3	134000
AC-1875F	1 7/8-12	3 3/4	5 7/16	11/16	3	2 1/4	1 7/8	3 1/2	240000
AC-2000F	2-12	3 3/4	5 7/16	11/16	3	2 1/4	1 7/8	3 1/2	240000

Offer of Sale

The items described in this document are hereby offered for sale at prices to be established by STARCYL Cylinder, and its authorized distributors. This offer and its acceptance by any customer ("Buyer") shall be governed by all of the following Terms and Conditions.

Buyer's order for any item described in its document, when communicated to STARCYL cylinder, or an authorized distributor ("Seller") verbally or in writing, shall constitute acceptance of this offer.

1. Terms and Conditions of Sale: All descriptions, quotations, proposals, offers, acknowledgments, acceptances and sales of Seller's products are subject to and shall be governed exclusively by the terms and conditions stated herein. Buyer's acceptance of any offer to sell is limited to these terms and conditions. Any terms or conditions in addition to, or inconsistent with those stated herein, proposed by Buyer in any acceptance of an offer by Seller, are hereby objected to. No such additional, different or inconsistent terms and conditions shall become part of the contract between Buyer and Seller unless expressly accepted in writing by Seller. Seller's acceptance of any offer to purchase by Buyer is expressly conditional upon Buyer's assent to all the terms and conditions stated herein, including any terms in addition to, or inconsistent with those contained in Buyer's offer. Acceptance of Seller's products shall in all events constitute such assent.

2. Payment: Payment shall be made by Buyer net 30 days from the date of delivery of the items purchased hereunder. Amounts not timely paid shall bear interest at the maximum rate permitted by law for each month or portion thereof that Buyer is late in making payment. Any claims by Buyer for omissions or shortages in a shipment shall be waived unless Seller receives notice thereof within 30 days after Buyer's receipt of the shipment.

3. Delivery: Unless otherwise provided on the face hereof, delivery shall be made F. O. B. Seller's plant. Regardless of the method of delivery, however, risk of loss shall pass to Buyer upon Seller's delivery to a carrier. Any delivery dates shown are approximate only and Seller shall have no liability for any delays in delivery.

4. Warranty: Seller warrants that the items sold hereunder shall be free from defects in material or workmanship for a period of 18 months from date of shipment to Buyer. THIS WARRANTY COMPRISES THE SOLE AND ENTIRE WARRANTY PERTAINING TO ITEMS PROVIDED HEREUNDER. SELLER MAKES NO OTHER WARRANTY, GUARANTEE, OR REPRESENTATION OF ANY KIND WHATSOEVER. ALL OTHER WARRANTIES, INCLUDING BUT NOT LIMITED TO, MERCHANTABILITY AND FITNESS FOR PURPOSE, WHETHER EXPRESS, IMPLIED, OR ARISING BY OPERATION OF LAW, TRADE USAGE, OR COURSE OF DEALING ARE HEREBY DISCLAIMED. NOTWITHSTANDING THE FOREGOING, THERE ARE NO WARRANTIES WHATSOEVER ON ITEMS BUILT OR ACQUIRED WHOLLY OR PARTIALLY, TO BUYER'S DESIGNS OR SPECIFICATIONS.

5. Limitation of Remedy: SELLER'S LIABILITY ARISING FROM OR IN ANY WAY CONNECTED WITH THE ITEMS SOLD OR THIS CONTRACT SHALL BE LIMITED EXCLUSIVELY TO REPAIR OR REPLACEMENT OF THE ITEMS SOLD OR REFUND OF THE PURCHASE PRICE PAID BY BUYER, AT SELLER'S SOLE OPTION. IN NO EVENT SHALL SELLER BE LIABLE FOR ANY INCIDENTAL, CONSEQUENTIAL OR SPECIAL DAMAGES OF ANY KIND OR NATURE WHATSOEVER, INCLUDING BUT NOT LIMITED TO LOST PROFITS ARISING FROM OR IN ANY WAY CONNECTED WITH THIS AGREEMENT OR ITEMS SOLD HEREUNDER, WHETHER ALLEGED TO ARISE FROM BREACH OF CONTRACT, EXPRESS OR IMPLIED WARRANTY, OR IN TORT, INCLUDING WITHOUT LIMITATION, NEGLIGENCE, FAILURE TO WARN OR STRICT LIABILITY.

6. Changes, Reschedules and Cancellations: Buyer may request to modify the designs or specifications for the items sold hereunder as well as the quantities and delivery dates thereof, or may request to cancel all or part of this order, however, no such requested modification or cancellation shall become part of the contract between Buyer and Seller unless accepted by Seller in a written amendment to this Agreement. Acceptance of any such requested modification or cancellation shall be at Seller's discretion, and shall be upon such terms and conditions as Seller may require.

7. Special Tooling: A tooling charge may be imposed for any special tooling, including without limitation, dies, fixtures, molds and patterns, acquired to manufacture items sold pursuant to this contract. Such special tooling shall be and remain Seller's property notwithstanding payment of any charges therefor by Buyer. In no event will Buyer acquire any interest in apparatus belonging to Seller which is utilized in the manufacture of the items sold hereunder, even if such apparatus has been specially converted or adapted for such manufacture and notwithstanding any charges paid by Buyer therefor. Unless otherwise agreed, Seller shall have the right to alter, discard or otherwise dispose of any special tooling or other property in its sole discretion at any time.

8. Buyer's Property: Any designs, tools, patterns, materials, drawings, confidential information or equipment furnished by Buyer or any other items which become Buyer's property, may be considered obsolete and may be destroyed by Seller after two (2) consecutive years have elapsed without Buyer placing an order for the items which are manufactured using such property. Seller shall not be responsible for any loss or damage to such property while it is in Seller's possession or control.

9. Taxes: Unless otherwise indicated on the face hereof, all prices and charges are exclusive of excise, sales, use, property, occupational or like taxes which may be imposed by any taxing authority upon the manufacture, sale or delivery of the items sold hereunder. If any such taxes must be paid by Seller or if Seller is liable for the collection of such tax, the amount thereof shall be in addition to the amounts for the items sold. Buyer agrees to pay all such taxes or to reimburse Seller therefor upon receipt of its invoice. If Buyer claims exemption from any sales, use or other tax imposed by any taxing authority, Buyer shall save Seller harmless from and against any such tax, together with any interest or penalties thereon which may be assessed if the items are held to be taxable.

10. Indemnity For Infringement of Intellectual Property Rights: Seller shall have no liability for infringement of any patents, trademarks, copyrights, trade dress, trade secrets or similar rights except as provided in this Part 10. Seller will defend and indemnify Buyer against allegations of infringement of U.S. patents, U.S. trademarks, copyrights, trade dress and trade secrets (hereinafter "Intellectual Property Rights"). Seller will defend at its expense and will pay the cost of any settlement or damages awarded in an action brought against Buyer based on an allegation that an item sold pursuant to this contract infringes the Intellectual Property Rights of a third party. Seller's obligation to defend and indemnify Buyer is contingent on Buyer notifying Seller within ten (10) days after Buyer becomes aware of such allegations of infringement, and Seller having sole control over the defense of any allegations or actions including all negotiations for settlement or compromise. If an item sold hereunder is subject to a claim that it infringes the Intellectual Property Rights of a third party, Seller may, at its sole expense and option, procure for Buyer the right to continue using said item, replace or modify said item so as to make it non-infringing, or offer to accept return of said item and return the purchase price less a reasonable allowance for depreciation. Notwithstanding the foregoing, Seller shall have no liability for claims of infringement based on information provided by Buyer, or directed to items delivered hereunder for which the designs are specified in whole or part by Buyer, or infringements resulting from the modification, combination or use in a system of any item sold hereunder. The foregoing provisions of this Part 10 shall constitute Seller's sole and exclusive liability and Buyer's sole and exclusive remedy for infringement of Intellectual Property Rights. If claim is based on information provided by Buyer or if the design for an item delivered hereunder is specified in whole or in part by Buyer, Buyer shall defend and indemnify Seller for all costs, expenses or judgments resulting from any claim that such item infringes any patent, trademark, copyright, trade dress, trade secret or any similar right.

11. Force Majeure: Seller does not assume the risk of and shall not be liable for delay or failure to perform any of Seller's obligations by reason of circumstances beyond the reasonable control of Seller (hereinafter 'Events of Force Majeure'). Events of Force Majeure shall include without limitation, accidents, act of God, strikes or labor disputes, acts, laws, rules or regulations of any government or government agency, fires, floods, delays or failures in delivery of carriers or suppliers, shortages of materials and any other cause beyond Seller's control.

12. Entire Agreement/Governing Law: The terms and conditions set forth herein, together with any amendments, modifications and any different terms or conditions expressly accepted by Seller in writing, shall constitute the entire Agreement concerning the items sold, and there are no oral or other representations or agreements which pertain thereto. This Agreement shall be governed in all respects by the law of the Province of Quebec, Canada. No actions arising out of the sale of the items sold hereunder or this Agreement may be brought by either party more than two (2) years after the cause of the action accrues.

HOW TO ORDER

ST5 SERIES

Medium Duty Hydraulic Cylinders

ST5 D F1 - 3.25 X 22.22 X 1.38 - #2

Bore*

Stroke*

Rod Dia*

FEATURE	DESCRIPTION	SYMBOL
SERIES	Used in All ST4 part number (AIR HD)	ST4
	Used in All ST5 part number	ST5

FEATURE	DESCRIPTION	PAGE NO.	SYMBOL
Double rod End	Used only if double rod cylinder is required	18	D
Back-to-Back	(must request drawing)		B
Position Sensor	Tempsonic Ready		X

FEATURE	DESCRIPTION	PAGE NO.	SYMBOL
Mounting Style	Head End Tie Rod Extended	6, 20	X3
	Cap End Tie Rods Extended	6, 20	X2
	Both End Tie Rod Extended	6, 20	X1
	Head Rectangular Flange	6	F1
	Cap Rectangular Flange	6	F2
	Head Square Flange	8	F5
	Cap Square Flange	8	F6
	Side Lugs	10, 22	S2
	Centerline Lugs	10, 22	S3
	Side Tapped	12, 22	S4
	Side End Lugs	12, 24	S7
	Head Trunnion	14, 26	T1
	Cap Trunnion	14, 26	T2
	Intermediate Fixed Trunnion Xi=()	14, 26	T4
	Cap Fixed Clevis	16, 24	P1
	Cap Detachable Clevis	16	P2
	Head Square Mount (8" BORE ONLY)	20	E3
	Cap Square Mount (8" BORE ONLY)	20	E4
	Head Rectangular Flange	18	E5
	Spherical Mounting	32,33	SB

FEATURE	DESCRIPTION	PAGE NO.	SYMBOL
Piston Rod End	Select :		
	Style #1 Intermediate Male	18	#1
	Style #2 Small Male	18	#2
	Style #3 Full Male	6	#3
	Style #4 Short Female		#4
	Style #5 Flange Coupling	23	#5
	Style #6 Plain	23	#6
	Style #7 Spherical female	33	#7
Style #X Special (Specify)		#X	

* SEE CATALOG PAGES FOR SELECTION OF BORE AND ROD SIZES COMBINATIONS

-S081 S061 C00 - LU - A1 - FP

FEATURE	DESCRIPTION	SYMBOL
Head Port	NPT Port SAE Straight Thread O-ring Port Flange Port (C.61) British Parallel British Tappered	N S F G R
Head Port Size	NPT use 1/4=04,3/8=06,....,1-1/4=20 SAE use 04, 06, 08, 10, 12, 16 look at catalog for std port size	
Head Ports Location	Head Location Std 1 (2,3,4)	1

FEATURE	DESCRIPTION	SYMBOL
Cap Port	NPT Port SAE Straight Thread O-ring Port Flange Port (C.61) British Parallel British Tappered	N S F G R
Cap Port Size	NPT use 1/4=04,3/8=06,....,1-1/4=20 SAE use 04, 06, 08, 10, 12, 16 look at catalog for std port size	
Cap Ports Location	Cap Location Std 1 (2,3,4 & 5*) * Backside	1

FEATURE	DESCRIPTION	SYMBOL
Cushion & Location	Head Non Cushion, Cap Non Cushion Head Cushion Only (where x = position 1,2,3,4) Cap Cushion Only (where x = position 1,2,3,4) Cushion both ends (where x = position 1,2,3,4)	C00 CX0 C0X CXX

Piston seals Option	DESCRIPTION	SYMBOL
	Buna U-cup With Backup	LB
	Viton U-cup With Teflon Backup	LV
	Urethane asymmetric U-cup seals (std)	LU
	Polypack Urethane U-cup	PU
	Polypack Viton U-cup	PV
	Hi-Load Piston	LH
	BUMPER SEALS (STAR4 ONLY)	BS
	Ring Packed	RP

Options	DESCRIPTION	SYMBOL
	Rod Extension C=	35 C=()
	Thread Extension A=	35 A=()
	Rod Scraper	35 A1
	Bleeder (Captive Ball Bearing/Set screw) pos.1,2,3,4	35 BA()*
	Bleeder (philips screw type) pos.1,2,3,4	35 BB()*
	Bleeder (standard Sae Port) pos.1,2,3,4	35 BC()*
	Aluminum Tubing (max 250 psi)	35 T1
	Alum. Tube With Magnet (max 250 psi)	35 T2
	Go Switches (round) Position 1,2,3,4	35 G1
	Go Switches Cylindicator, Pos, 1 2 3 4	35 H1
	Stop Tube (length)	ST()
	Stop Tube Double piston (length)	STD()
	Rod Boot	R1
	Chomed Rod	35 R2
	Nitrotec Rod	35 R3
	Stainless Steel Rod	S1

FP = Finish Paint
FM = Finish Starnite
FN = Finish Nickel

Port & Adjustable Cushion Location

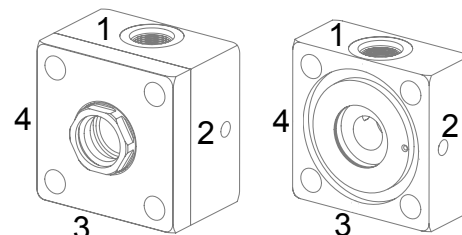

BORE	STD PORT PER BORE				STD PORT LOCATION HEAD , CAP
	EE				
	NPTF	CODE	SAE	CODE	
1 1/2	3/8	06	6	06	1,1
2	3/8	06	6	06	1,1
2 1/2	3/8	06	6	06	1,1
3 1/4	1/2	08	10	10	1,1
4	1/2	08	10	10	1,1
5	1/2	08	10	10	1,1
6	3/4	12	12	12	1,1
8	3/4	12	12	12	1,1



STARCYL CYLINDERS

STARCYL CYLINDERS
SPACE-SAVIER AIR CYLINDERS

SINGLE OR MULTI-STAGE

THE ONLY CYLINDER UPGRADABLE!

**Not Enough Force
Don't Change The Design
Add A Stage!**

STAR 1 SERIES

STAR1 - Multistage Upgradable air cylinders

STARCYL CYLINDERS
SPACE-SAVIER

STAR2 SERIES

- ☑ Bore size from 1 1/2" to 10"
- ☑ Stroke up to 40"
- ☑ Save Space up to 35%
- ☑ 250 PSI AIR, OIL
- ☑ Two-Year Warranty
- ☑ Economic design

NFPA STYLE MOUNT

STAR2 - NFPA style Mount spacesaver air cylinders

STARCYL AIR CYLINDERS

...To boldly go where no cylinder has gone before ...

STAR3 SERIES
WWW.STARCYL.COM

- ☑ NFPA, Interchangeable, Heavy Duty Air Cylinders
- ☑ Flush Bore - standard
- ☑ 11 Bore sizes From 1.5" through 12"
- ☑ Stroke - available to any practical length
- ☑ 18 standard Mounting Styles
- ☑ Adjustable Air Cushion Standard
- ☑ 250 PSI AIR/OIL
- ☑ Two Year Warranty
- ☑ Economic Design

STAR3 - Heavy Duty NFPA interchangeable air cylinders Aluminum construction

STARCYL AIR CYLINDERS

NFPA ROD LOCK CYLINDER

ST3RL option

FEATURES	BENEFITS
No Rod Displacement on Engagement	Maintains Accurate Positioning
Large Clamping Surface	Consistent Clamping Force
IP67 Rated (Exceeds NEMA 4X)	Suitable for Wash-Down Areas
Fast Response Time	High Cycle Life Accuracy
Extremely Low Backlash	Precision Holding
Spring Engaged Units	Holds Load During Power/Pressure Loss
Rated for 2,750,000 Cycles	Long Maintenance-Free Life
4 bar (60 psi) Release Pressure	Compact Unit, Easy Integration
	Broad Application

ST3RL - NFPA Rod Lock for STAR3 air cylinders

STARCYL AIR CYLINDERS

SPACE ONE
Space. The Final Frontier ...

Space Saver Air Cylinders

SO - Space One, Spacesaver Air Cylinder

STARCYL CYLINDERS

HEAVY DUTY Hydraulic Cylinders

STAR6 SERIES

HEAVY DUTY SERVICE INDUSTRIAL TIE ROD CONSTRUCTION

NOMINAL PRESSURE - 3000 PSI

STANDARD BORE SIZES 1.5" THROUGH 6" PISTON ROD DIAMETERS 1.5" THROUGH 4" 18 STANDARD MOUNTING STYLES STARITE™ AVAILABLE ON ALL STEEL PARTS

STAR6 - Heavy Duty NFPA interchangeable Hydraulic cylinders, 3000 psi

STARCYL AIR CYLINDERS

MULTI-STAGES

M3 SERIES

MULTI-STAGES NFPA STYLE MOUNT HEAVY DUTY - HIGH FLOW

NOMINAL PRESSURE - AIR 250 PSI

STANDARD BORE SIZES 1.5" THROUGH 10" STROKE UP TO 12" NFPA STYLE MOUNT TWO-YEAR WARRANTY

M3 - Heavy Duty NFPA Multi-stages air cylinders High Flow

STARCYL CYLINDERS

ISOMETRIC SERIES

AIR CYLINDER ISO 6432 ISO 15552

STMM - Isometric series ISO 6432 & 15552 Air Cylinder

WWW.STARCYL.COM

YOUR STARCYL DISTRIBUTOR:

STARCYL CYLINDERS
877-STARCYL

FAX: (630) 282-7142

IN CANADA: PH: 450-688-0505 - FAX 514-221-3798



ST5-DEC09